

Landeyjahöfn harbour preliminary independent evaluation

Data review and assessment of harbour utilization

Prepared for the Ministry of Transport and Local Government



Vatnaskil report no. 20.07

LVRS-Consultancy report no. 2020-L-I

October 2020

Mannvit
Urðarhvarf 6
203 Kópavogur
Iceland

Tel. +354-422-3000
mannvit@mannvit.is
www.mannvit.is

Vatnaskil
Síðumúli 28
108 Reykjavík
Iceland

Tel. +354-568-1766
vatnaskil@vatnaskil.is
www.vatnaskil.is

Leo van Rijn Sediment
(LVRS Consultancy)
Domineeswal 6
8356DS Blokzijl
Netherlands

Tel. +31-527-292289
info@leovanrijn-sediment.com
www.leovanrijn-sediment.com



| | | | |
|---|-----------------------------------|--|--|
| Report no: 20.07 / 2020-L-I | Published: October 2020 | Number of pages: 86 | Distribution: Open <input checked="" type="checkbox"/> Closed <input type="checkbox"/> |
| Report title: Landeyjahöfn harbour preliminary independent evaluation. Data review and assessment of harbour utilization. | | | |
| Authors: Gísli S. Pétursson, Leo van Rijn, Sveinn Óli Pálmarsson, Eric M. Myer, Einar Ragnarsson | | | |
| Project manager: Sveinn Óli Pálmarsson | | | |
| Abstract: <p>Since the opening of Landeyjahöfn harbour in 2010, sedimentation problems and harsh wave climate have resulted in limited utilization of the harbour. Mitigation measures focused on maintenance dredging have been costly and insufficient at ensuring reliable ferry operation. The Ministry of Transport and Local Government commissioned an independent evaluation of the Landeyjahöfn harbour in response to a parliamentary resolution calling for solutions to improve harbour utilization. The evaluation was designed as a preliminary study to review and assess available information to address as much as possible the goals of the parliamentary resolution and outline further measures necessary to fulfil those goals.</p> <p>A review of available data was performed. Overall, available measurement data appear to be of good quality and encompass most key natural processes affecting the conditions near the harbour. Furthermore, reporting has been made on most relevant factors addressed in the preparation, construction and operational phases of the harbour. However, during the review process several important information gaps were discovered, including measurements and analyses relating to ocean forcing and sedimentation processes, historical maintenance dredging measures and harbour utilization. Some gaps were partially filled during the present evaluation; however, additional gaps remain which must be addressed to complete a comprehensive evaluation.</p> <p>The main mitigation measure for improving harbour utilization to date has been maintenance dredging, which has been performed on a regular basis since opening of the harbour. Dredging quantities were severely underestimated in pre-construction studies. A new evaluation of sedimentation rates in the harbour was performed. It suggests that the degree of sedimentation experienced since the harbour opened gives a good indication of the sedimentation that can be expected in the future for the harbour in its current state. A new ferry with less draught was put into service in July of 2019 and appears to have improved utilization of the harbour, although more time is needed for data collection and evaluation to determine the degree of improvement.</p> <p>Despite improved navigability of the new ferry, some form of improvement measures is necessary to achieve significant increase in the utilization of the harbour in its current state. Two main concepts for potential improvement measures were identified. A shelter concept involves implementation of structures aimed at providing shelter from high waves breaking on the outer bar, with the goal of improving navigational conditions between the outer bar and the harbour entrance. Maintenance dredging would still be required in conjunction with shelter techniques, but those operations would benefit from the shelter effects. A new harbour concept, on the other hand, has the potential to eliminate regular maintenance dredging operations altogether while ensuring safe navigational conditions unaffected by breaking waves on the outer bar.</p> <p>A roadmap is provided, outlining additional steps required to complete a comprehensive independent evaluation of Landeyjahöfn harbour that fully addresses the questions laid out in the parliamentary resolution.</p> | | | |
| Client: Ministry of Transport and Local Government | | Client representative: Árni Freyr Stefánsson | |
| Keywords: Landeyjahöfn, Iceland, harbour, review, assessment, sediment, wave, tidal, navigation, utilization | | | |



Contents

| | |
|---|----|
| Contents..... | 5 |
| Figures | 7 |
| Tables..... | 9 |
| Samantekt (Icelandic summary)..... | 10 |
| 1 Introduction..... | 15 |
| 2 Review of available existing data..... | 17 |
| 2.1 Site conditions at Landeyjahöfn harbour | 21 |
| 2.1.1 Weather, waves and currents | 21 |
| 2.1.2 Sediments and bathymetry..... | 26 |
| 2.1.3 Navigational conditions | 29 |
| 2.2 Pre-construction hydro-morphodynamic studies..... | 29 |
| 2.2.1 Annual waves, extreme storm waves and currents | 29 |
| 2.2.2 Historical shorelines, longshore sand transport and overall sediment budget | 33 |
| 2.2.3 Morphological behaviour of the outer bar | 34 |
| 2.2.4 Morphological behaviour at the harbour entrance | 36 |
| 2.2.5 Shoreline morphology | 37 |
| 2.2.6 Sedimentation inside the harbour | 38 |
| 2.3 Post-construction hydro-morphodynamic studies | 39 |
| 2.3.1 Annual waves, extreme storm waves and currents | 39 |
| 2.3.2 Historical shorelines, longshore sand transport and overall sediment budget | 41 |
| 2.3.3 Morphological behaviour at the harbour entrance | 42 |
| 2.3.4 Sedimentation inside the harbour | 48 |
| 2.3.5 Shoreline morphology | 48 |
| 2.3.6 Dredging volumes..... | 49 |
| 2.4 Information gaps..... | 49 |
| 3 Additional data collection and analysis..... | 50 |
| 3.1 Operational data regarding the ferry..... | 50 |
| 3.2 Analysis of longshore transport | 51 |
| 3.2.1 Methods..... | 51 |
| 3.2.2 Prediction results..... | 54 |
| 3.3 Analysis of sedimentation in the harbour | 58 |
| 3.3.1 Bathymetry schematization | 59 |

| | | |
|-------|--|----|
| 3.3.2 | Prediction method and input data | 60 |
| 3.3.3 | Predicted deposition volumes | 61 |
| 4 | Assessment of implemented mitigation measures | 63 |
| 4.1 | Implementation of new ferry | 63 |
| 4.1.1 | Ferry specifications..... | 63 |
| 4.1.2 | Factors limiting ferry operation | 64 |
| 4.2 | Maintenance dredging | 65 |
| 4.3 | Recommendations for identifying future improvement measures | 67 |
| 5 | Roadmap towards a comprehensive, independent evaluation | 69 |
| 5.1 | Fill information gaps – Further data collection and analysis..... | 69 |
| 5.2 | Define baseline case for future harbour operation without improvement measures | 70 |
| 5.3 | Identify and examine potential improvement measures..... | 71 |
| 5.3.1 | Shelter concept | 71 |
| 5.3.2 | New harbour concept..... | 73 |
| 5.4 | Compare and assess viability of improvement measures | 74 |
| 6 | Concluding remarks | 75 |
| | References | 76 |
| | Annex..... | 79 |
| A. | SEDHAR-SAND: Sedimentation of sand and mud in harbour entrance and basin | 79 |

Figures

| | |
|--|----|
| Figure 1. Dates of available bathymetric surveys shown as points. Red points show surveys over a large area, blue points show surveys in the vicinity of the harbour, cyan points show specific surveys of dumping zones and yellow points show specific surveys of the outer bar. Total number of surveys are shown for months and years under the Tot. column and row respectively. | 19 |
| Figure 2. Wind rose for Landeyjahöfn harbour weather station. | 22 |
| Figure 3. Offshore wind rose from Stórhöfði, located about 30 km south-south-west of Landeyjahöfn. | 22 |
| Figure 4. Location of wave buoys and their operational periods. | 23 |
| Figure 5. Offshore wave rose (left upper) and nearshore wave roses (lower) (DHI, 2006; DHI, 2007). Stations 4,5 and 6 are indicated on the map with white dots. | 24 |
| Figure 6. Wave propagation from 4 directions towards harbour location (Viggosson, Jónsdóttir, Sigurðarson, & Bernóðusson, 2005). | 25 |
| Figure 7. Bathymetry in July 2004 and May 2006 (DHI, 2007). | 28 |
| Figure 8. Typical cross-shore profiles (DHI, 2006). | 28 |
| Figure 9. Computed wave heights and patterns for storm from southwest (DHI, 2007). | 30 |
| Figure 10. Computed tidal elevations and tidal currents, depth 10 m.; March 2004 (blue dots are model results from the Icelandic Maritime Administration) (DHI,2007). | 31 |
| Figure 11. Computed current patterns for waves from the south (upper) and from the southwest (lower) (DHI,2007). | 32 |
| Figure 12. Computed wave height at 4 locations for a storm in November 1985 along a navigation line normal to harbour entrance (DHI,2007). | 33 |
| Figure 13. Computed mean and maximum current velocity along a navigation line normal to harbour entrance: November 1985 (upper) and February 1989 (lower) (DHI,2007). | 33 |
| Figure 14. Longshore sand transport based on 1D LITPACK-model at harbour location; annual values (left) and monthly-averaged (right) (DHI,2006; 2007). | 34 |
| Figure 15. Computed cross-shore distribution of longshore transport at the proposed harbour location (DHI,2006;2007). | 34 |
| Figure 16. Sediment transport during February 1989 storm (DHI,2007). | 35 |
| Figure 17. Final model bathymetry for rough south-westerly wave conditions following a starting bathymetry in May 2006 (DHI, 2007). | 36 |
| Figure 18. Configuration of breakwater tips (DHI,2007). | 37 |
| Figure 19. Computed shoreline development on west and east side of harbour (DHI,2007). | 37 |
| Figure 20. Equilibrium coastline after 10 years in MIKE21FM (DHI,2007). | 38 |
| Figure 21. Computed wave patterns (left) on March 6, 2011. The wave rose (right) is based on model data from the right buoy location. The red circle shows the wave direction and wave height used for the computed wave patterns. A composite of figures in (DHI, 2013). | 40 |
| Figure 22. Location of coastal profiles (DHI,2013). | 41 |

| | |
|---|----|
| Figure 23. Computed wave roses based on revised model (1958-2012 modelled wave data) at depth of 15 m (DHI,2013). | 41 |
| Figure 24. Longshore sand transport for an average year; locations of harbour and river are indicated (DHI,2013). | 42 |
| Figure 25. Cross-shore bed profiles at location 500 m west of harbour (DHI,2013). | 43 |
| Figure 26. Proposal for detached breakwaters by DHI (2013). | 44 |
| Figure 27. Large reservoirs on both sides of harbour (DHI,2013). | 44 |
| Figure 28. Weekly estimated longshore transport for the year 2019 at 10 m depth in front of the harbour entrance (location shown to the right) compared to the average transport for the period week 27 in 2010 to week 5 in 2020. A composite of figures from IRCA (2020). | 46 |
| Figure 29. Definition of survey areas (IRCA, 2015c). | 46 |
| Figure 30. Bathymetry December 27, 2017 (top), January 5, 2018 (middle) and difference map (bottom) (IRCA, 2018b). | 47 |
| Figure 31. Overview of IRCA (2018a) monitoring points. | 48 |
| Figure 32. Shoreline around Landeyjahöfn harbour, Iceland. Photo taken by Guðmundur Alfreðsson on 25/09/2012 (DHI, 2013). | 49 |
| Figure 33. Cross-shore distribution of significant wave height, longshore velocity and longshore sand transport for 4 storm events based on CROSMOR-model. | 55 |
| Figure 34. Wave rose for nearshore wave buoy BFK at depth of about 30 m (preliminary analysis). | 56 |
| Figure 35. Wave exceedance curve for nearshore wave buoy BFK at depth of about 30 m (preliminary analysis). | 57 |
| Figure 36. Peak wave period and significant wave height for nearshore wave buoy BFK at depth of about 30 m (preliminary analysis). | 57 |
| Figure 37. Bathymetry maps from 2009, 2014 and 2019. A composite figure from bathymetric surveys performed by IRCA on October 10, 2009, July 29, 2014 and May 9, 2019. | 59 |
| Figure 38. Schematization of deposition processes in harbour entrance and approach channel. | 60 |
| Figure 39. The harbour entrance for the proposed layout of the land-based dredging system (DHI,2018). | 66 |
| Figure 40. Wave height with (lower) and without (upper) detached breakwaters for conditions on March 7, 2010 at 18:00 (IRCA, 2015d). | 72 |
| Figure 41. An idea for an island-harbour layout from the planning stages of Landeyjahöfn harbour. | 74 |



Tables

| | |
|---|----|
| Table 1. List of reports and memos handed over by the IRCA..... | 17 |
| Table 2. Results of a Weibull extrapolation of statistical analysis for measured buoy data for Surtsey data (1988 – 2004) and Bakkafjara data (November 2003 to March 2005, buoy BFD1, see Figure 4)) (Viggosson, Jónsdóttir, Sigurðarson, & Bernóðusson, 2005). | 24 |
| Table 3. Predicted sedimentation rates inside harbour basin after construction for three entrance widths (DHI,2007). | 39 |
| Table 4. Depth changes near harbour entrance over period January 2016 - July 2018..... | 48 |
| Table 5. Dredging volumes from IRCA dredging summary documents..... | 49 |
| Table 6. Longshore transport rates for storm events..... | 54 |
| Table 7. Wave rose data for nearshore wave buoy BFK at depth of about 30 m (preliminary analysis). | 56 |
| Table 8. Computed longshore sand transport rates for annual mean wave conditions; offshore depth = 30 m, $d_{50} = 0.35$ mm; surf zone slope 1 to 100; wave breaking coefficient = 0.6. The red numbers represent the values for Landeyjahöfn harbour. | 58 |
| Table 9. Input data of SEDHAR-SAND model. | 61 |
| Table 10. Predicted annual deposition volumes. | 62 |

Samantekt (Icelandic summary)

Inngangur

Landeyjahöfn er ferjuhöfn við Bakkafjöru á suðurströnd Íslands. Höfnin þjónustar Herjólf, ferju sem siglir milli hafnarinnar og Vestmannaeyja. Hafnargerð hófst í ágúst 2008. Frá opnun hafnarinnar sumarið 2010 hefur sandburður til hennar verið til mikilla vandræða og leitt til takmarkaðrar nýtingar hafnarinnar, sérstaklega yfir vetrarmánuðina. Enn fremur hafa slæm skilyrði utan hafnarinnar vegna öldufars gert innsiglingu erfiða og takmarkað nýtingu hafnarinnar enn frekar.

Dýpkunarpörf hefur verið umtalsvert meiri en gert var ráð fyrir með auknum ófyrirséðum rekstrar-kostnaði. Á veturna eru aðstæður oft erfiðar til dýpkunaraðgerða sem eru háðar veðri, sjólagi og öldufari. Þrátt fyrir miklar og kostnaðarsamar dýpkunaraðgerðir hefur Herjólfur engu að síður ekki getað siglt til Landeyjahafnar stóran hluta tímans.

Í byrjun desember 2019 fól Alþingi samgöngu- og sveitarstjórnarráðherra að hefja óháða úttekt á Landeyjahöfn í samræmi við samgönguáætlun fyrir árin 2019-2033 og fimm ára samgönguáætlun fyrir árin 2019-2023. Lögð var áhersla á mikilvægi þess að flýta úttekt óháðra aðila á Landeyjahöfn þar sem ástandið í höfninni gæti ekki talist boðlegt íbúum Vestmannaeyja né öðrum sem treysta þurfa á greiðar samgöngur milli lands og Eyja. Við þingsmeðferð ályktunarinnar komu fram sjónarmið um að líta verði til allra þátta sem geta haft áhrif á nýtingu hafnarinnar við gerð úttekta. Jafnframt var óskað eftir að í úttektinni yrði eftirfarandi spurningum svarað:

1. Er hægt að gera þær úrbætur á Landeyjahöfn að dýpkunarpörfin minnki verulega eða hverfi?
2. Í hverju fælust slíkar úrbætur og hver er áætlaður kostnaður við þær?
3. Ef slíkar endurbætur þættu ekki gerlegar, af tæknilegum eða fjárhagslegum ástæðum, til hvers konar dýpkunaraðgerða þyrfti þá að grípa til að halda höfninni opinni allan ársins hring?

Samgöngu- og sveitarstjórnarráðuneytið skilgreindi frekar úttektina og þann ramma sem þeirri vinnu væri settur að sinni, þótt á þeim tíma væri ekki vitað hver yrðu tiltæk gögn og aðrar upplýsingar fyrir úttektina. Úttektinni var ætlað greina tiltæk gögn tengd Landeyjahöfn um setflutning, sjólag og nýtingu hafnarinnar sem Vegagerðin myndi afhenda og mögulega aðrir aðilar. Jafnframt að leggja fram tillögur um úrbætur tengdar framangreindum þáttum byggt á rýni á tiltækum upplýsingum. Ef úttektin myndi leiða í ljós að frekari vinna, þ.m.t. gagnasöfnun og -greiningar, þyrfti að fara fram til að unnt verði að draga fram tillögur að úrbótum og svara spurningum þingsályktunartillögunnar, væri sú vinna utan skilgreinds ramma úttekta að sinni.

Ráðuneytið afmarkaði úttektina þannig að hún myndi nýta sem best tiltæk gögn til að veita innlegg í úrbótatillögur og svör við spurningum þingsályktunartillögunnar. Jafnframt að skilgreina eins og hægt er hvaða ráðstafanir þurfi að gera til að svara þeim fyllilega. Í verkefninu nú eru því tekin fyrstu skref í átt að heildstæðri óháðri úttekt á Landeyjahöfn eins og Alþingi skilgreindi hana. Sú vegferð er nánar kortlögð m.a. með því að tryggja að tekið verði tillit til tiltækra gagna og fyllt í mikilvægar glufur í gagnasöfnuninni.

Í skýrslunni er greint frá rýni úttekta aðila á tiltækum gögnum sem voru afhent vegna úttekta. Bæði er horft til þeirra gagna og upplýsinga sem urðu til í aðdragandi byggingar hafnarinnar og eftir að hún var tekin í notkun. Meginþættir í gagnasafninu sem ráða þarf bót á í úttektaferlinu eru listaðir, auk þess sem viðbótar gagnasöfnun og gagnagreining fór fram að hluta í verkinu. Lagt er mat á þær mótvægisáðgerðir sem þegar hafa verið reyndar við rekstur hafnarinnar. Jafnframt eru lagðar fram ráðleggingar fyrir mat á mögulegum endurbótum á höfninni. Að lokum er kortlagt það ferli sem þarf



að fara fram til að svara fyllilega spurningum þingsályktunartillögunnar og þannig mynda heildstæða óháða úttekt á Landeyjahöfn.

Rýni fyrirbyggjandi gagna

Vegagerðin afhenti mikið magn gagna fyrir úttektina sem snúa aðallega að uppbyggingu hafnarinnar og sandflutningsmálum. Má þar m.a. finna skýrslur, minnisblöð og ýmsar mælingar sem safnað hefur verið nærri höfninni bæði fyrir og eftir framkvæmdir. Jafnframt var gögnum og upplýsingum safnað frá öðrum aðilum. Almenn virðast mæld gögn vera góð og ná utan um flesta meginþætti sem áhrif hafa á aðstæður nærri höfninni. Lagður er fram listi yfir skýrslur og minnisblöð sem Vegagerðin afhenti. Greinargerðir frá því áður en höfnin var byggð gera grein fyrir undirbúnings- og hönnunarferli hafnarinnar. Hins vegar hafa greinargerðir eftir byggingu hafnarinnar aðallega snúið að setflutningi og tilsvarendi öldufari, þ.m.t. botnhæðarbreytingum og dýpkunaraðgerðum.

Vegagerðin afhenti stórt safn korta og skjala sem greina frá botndýptarmælingum frá 2002 til 2020, sérstaklega í tengslum við dýpkunaraðgerðir. Gerð er nánari grein fyrir þessum gögnum og yfirlit tekið saman yfir þau í skýrslunni. Gögn lágu einnig fyrir um greiningu kornastærða setefna frá mismunandi sýnatökum bæði fyrir og eftir byggingu hafnarinnar. Helstu önnur gögn snéru að öldumælingum, sjávarhæðarmælingum, gagnamyndum frá radarmælingum við höfnina og veðurgögnum.

Umhverfi Landeyjahafnar einkennist af svörtum fjörusandi fyrir opnu hafi. Veður verður oft vont á svæðinu og háar öldur berast að landi auk þess sem sandflutningur getur verið verulegur. Markarfljót rennur til sjávar rétt austan hafnarinnar og ber það með sér töluvert magn setefna. Suðvestan alda er ríkjandi og getur ölduhæð orðið mjög há og tíð. Um 800-1200 m frá landi liggur sandrif á um 4-8 m dýpi, en milli lands og rifs er renna á um 8-12 m dýpi. Framan við höfnina er hlið í rifinu þar sem dýpi er meira en annars staðar við það. Rifið er á hreyfingu árstíðabundið og milli ára, en hegðun rifsins er ekki fyllilega útskýrð.

Í skýrslunni er fjallað um helstu þætti sem skoðaðir hafa verið í tengslum við höfnina, bæði frá undirbúnings- og hönnunarferli og þeim rannsóknum sem fóru fram eftir að höfnin var tekin í rekstur.

Þrátt fyrir að tiltæk gögn séu almennt góð og greinargerðir gefi til kynna margþætta skoðun á aðstæðum, kom í ljós að eitt og annað vantar inn í þá mynd svo unnt sé að svara þeim spurningum sem lágu fyrir úttektinni. Meginþættir sem ráða þarf bót á í úttektarferlinu eru dregin saman í eftirfarandi flokka: straum- og ölduálag sjávar gagnvart setflutningum, setmyndun, dýpkunaraðgerðir, sjólag utan hafnar, rekstur ferju og nýtni hafnar. Söfnun frekari gagna og framkvæmd greininga er utan ramma verkefnisins nú og bíður síðari stiga í úttektarferlinu. Úttektarhópurinn mat það hins vegar þannig að nauðsynlegt væri í núverandi úttekt að bæta að hluta þætti tengda rekstri ferjunnar og setflutningsmálum við höfnina svo unnt væri að skilgreina næstu skref í þeirri vegferð að klára heildstæða úttekt á Landeyjahöfn.

Frekari gagnasöfnun og greining

Við vinnslu úttektarinnar lágu ekki fyrir gögn er varða nýtingu hafnarinnar, sjólag, viðhorf sjófarenda til aðstæðna og þá þætti sem hafa ráðið hvað mestu gagnvart ákvörðunum um siglingu til hafnarinnar við mismunandi aðstæður. Enn fremur liggur ekki fyrir greining á nýtingartíma hafnarinnar. Úttektar-aðilar ákváðu því að fara í vettvangsferð til Landeyjahafnar og um borð í Herjólf til að fá betri sýn á sjónarhorn sjófarenda og rekstraraðila hafnarinnar gagnvart nýtingu hennar. Ferðin gaf góða sýn á helstu þætti sem horft er til við siglingu til og frá höfninni sem og nýtingu hennar. Eftir sem áður er

mikilvægt að framkvæma greiningu á nýtingartíma hafnarinnar til þessa og setja í samhengi við ákvarðanir um siglingu til hafnarinnar við mismunandi aðstæður.

Helstu áhyggjur sjófarenda eru af þeim þáttum sem ráða mestu gagnvart innsiglingu til hafnarinnar, þ.e. ölduhæð og sveiflutíma öldu milli hafnarmynnis og náttúrulegs rifs sem liggur um 300-500 m utan við höfnina (um 800-1200 m frá landi). Dýpkunaraðgerðir eru jafnframt takmarkaðar af þessum þáttum og er því til mikils að vinna að lagfæra þætti er snúa að sjólagi og öldufari milli rifsins og hafnarinnar. Horft er sérstaklega til þessara þátta við kortlagningu að heildarúttekt og þeirra meginleiða sem þarf að fara við fullnustu hennar.

Sandflutningur utan hafnarinnar og setmyndun við hana er viðvarandi vandamál. Eru því allar líkur á að dýpkunarpörf verði áfram til staðar um ókomin ár fyrir núverandi höfn. Fyrri rannsóknir hafa verulega vanmetið setmyndunina og dýpkunarpörf á svæðinu. Enn fremur var ekki gert ráð fyrir að þörf væri á dýpkunaraðgerðum utan hafnarinnar eða við rífið nema á nokkurra ára fresti eftir storma við sérlega óheppilegar aðstæður. Við úttektina nú var lagt mat á setmyndun setefna sem berast til hafnarinnar og að innsiglingu hennar. Er matið í góðu samræmi við raunmagn sem dælt hefur verið upp á svæðinu, eða um 0,2 – 0,6 milljón rúmmetra á ársgrunni. Setmyndun til þessa við Landeyjahöfn gefur því vel til kynna þá setmyndum sem hafa þarf til viðmiðunar vegna framtíðarreksturs hafnarinnar fyrir óbreytt dýptarviðmið.

Mat á mótvægisáðgerðum hingað til

Til að bregðast við mikilli setmyndun sem fylgdi í kjölfar opunar Landeyjahafnar árið 2010 var ráðist í dýpkunaraðgerðir og hafa þær farið reglulega fram síðan. Viðhaldsdýpkanir hafa aðallega verið gerðar með skipum. Gerðar hafa verið tilraunir með fyrirbyggjandi dýpkunaraðgerðir en ekki hefur virkni þeirra verið metin. Þrátt fyrir umfangsmiklar dýpkunaraðgerðir hefur höfnin verið lokuð í samtals 2-5 mánuði á ári frá opnun hennar. Tilraun var gerð til uppsetningar fasts dælubúnaðar frá landi við hafnarmynnið til að minnka dýpkunarpörf með skipum. Þessi leið reyndist ekki ákjósanleg þar sem búnaðurinn þrengdi hafnarmynnið. Var reiknað með að það gæti valdið verulegum takmörkunum við innsiglingu til hafnarinnar, sér í lagi í vondu veðri.

Vandkvæði vegna siglingar ferjunnar við þessa miklu setsöfnun mátti að hluta rekja til þess að ný ferja með minni djúpristu hafði ekki verið tekin í notkun líkt og gert hafði verið ráð fyrir á hönnunarstigi hafnarinnar. Með tilkomu nýrrar ferju sumarið 2019 hefur dýpi spilað minna hlutverk í ákvörðunum hverju sinni um siglingu til hafnarinnar þar sem ný ferja hefur minni djúpristu en eldri ferja. Hefur því erfitt sjólag og öldufar milli rifs og hafnar vegið þeim mun þyngra í slíkum ákvörðunum. Bent hefur þó verið á að setmyndun síðastliðið ár virðist hafa verið heldur minni en á liðnum árum, en það á eftir að staðfesta frekar. Sjófarendur virðast almennt vera ánægðir með tilkomu nýrrar ferju og telja sig hafa betri stjórn á henni en forvera hennar. Byggt á forgreiningu mjög takmarkaðra gagna um ferðir til Landeyjahafnar virðist ný ferja hafa leitt til betri nýtni hafnarinnar. Þetta þarf þó að skoða mun nánar á seinni stigum úttektar, og mun tíminn einnig þurfa að leiða í ljós hversu mikil aukning verður í nýtingu Landeyjahafnar með nýrri ferju.

Þrátt fyrir tilkomu nýrrar ferju verða einhverskonar endurbætur nauðsynlegar til að ná fram verulega bættri nýtingu hafnarinnar. Ekki mun duga að halda úti dýpkunaraðgerðum þar sem erfitt sjólag utan hafnar takmarkar oft á tíðum siglingar að höfninni. Ræður þar mestu um háar öldur sem gjarnan brotna á rífinu sem liggur utan hafnar og valda erfiðum aðstæðum til siglinga.

Ráðleggingar fyrir mat á mögulegum endurbótum á höfninni

Helstu þætti sem takmarka siglingu ferjunnar ásamt reynslunni sem komin er af dýpkunaraðgerðum þarf að setja í samhengi við mat á setmyndun og öldufari nærri höfninni. Í skýrslunni er þetta gert að því marki sem unnt er nú til að fá fram innlegg í þær spurningar sem lagðar voru fram í þingsályktuninni. Sér í lagi má af þessu ráða að þörf er á endurbótum á höfninni til að ná markmiðum um stóraukna nýtingu hennar þar sem mótvægisáðgerðir hingað til hafa ekki dugað. Með þetta í huga má draga fram eins konar frummat á þeim álitamálum sem tilgreind eru í spurningum þingsályktunarinnar:

1. Er hægt að gera þær úrbætur á Landeyjahöfn að dýpkunarpörfin minnki verulega eða hverfi?

Setmyndun til þessa við Landeyjahöfn gefur vel til kynna hver setmyndun verður sem taka þarf tillit til við framtíðarrekstur hafnarinnar fyrir óbreytt dýptarviðmið.

Til að minnka verulega dýpkunarpörf þarf að ákvarða mögulegt dýpkunarfyrirkomulag sem tekur tilliti til nýju ferjunnar og þeirrar reynslu sem fengist hefur á nýtingu hafnarinnar. Slíkt fyrirkomulag væri borið saman við dýpkunaraðgerðir hingað til svo meta megi hvort dýpkunarpörf sé líkleg til að minnka.

Aðgerðir sem leiða til skjólmyndunar milli rifs og hafnarmynniss gagnvart háum öldum myndu bæta siglingarhæfi ferjunnar milli rifs og hafnar og eru líklegar til að styðja við dýpkunaraðgerðir. Mikilvægt er að greina slíkar aðgerðir frekar og leggja mat á virkni þeirra og hvort einhver vandkvæði kunna að vera líkleg vegna þeirra.

Ólíklegt er að unnt sé að gera endurbætur á höfninni eins og hún er í dag þannig að dýpkunarpörf hverfi. Til þess að slíkt markmið náist er líklegra að endurbætur þurfi að fela í sér róttækar lausnir sem krefjast endurhönnunar hafnarinnar. Slíka lausn þyrfti að skilgreina vel og meta til samanburðar við aðrar lausnir til endurbóta á höfninni. Dæmi um slíka útfærslu væri að byggja nýja höfn utan við rífið sem tengd væri eldri höfn með brú.

2. Í hverju fælust slíkar úrbætur og hver er áætlaður kostnaður við þær?

Leiðin til að svara þessu hefur verið kortlögð í skýrslunni með vegvísi að heildstæðri óháðri úttekt á Landeyjahöfn. Þar eru lagðar fram ráðleggingar til að draga fram og meta mögulegar endurbætur á höfninni. Munu þar annars vegar vera lagðar til grundvallar aðgerðir sem leiða til skjólmyndunar utan hafnar og hins vegar lausnir sem krefjast endurhönnunar hafnarinnar. Samanburður endurbóta verður bæði gerður út frá tæknilegum sjónarmiðum og kostnaði.

3. Ef slíkar endurbætur þættu ekki gerlegar, af tæknilegum eða fjárhagslegum ástæðum, til hvers konar dýpkunaraðgerða þyrfti þá að grípa til að halda höfninni opinni allan ársins hring?

Of snemmt er að segja til um hvort endurbætur kunna að vera gerlegar. Vegvísirinn að heildstæðri óháðri úttekt á Landeyjahöfn gerir ráð fyrir bæði tæknilegu mati og kostnaðarmati á mögulegum endurbótum. Enn fremur er gerður samanburður við grunntilfelli sem gerir ráð fyrir nýju ferjunni og nauðsynlegum dýpkunaraðgerðum, en engum beinum endurbótum á höfninni. Mikilvægt er hins vegar að hafa í huga að setmyndun er ekki eini þátturinn sem takmarkar siglingar ferjunnar. Öldufar hefur einnig veruleg áhrif. Þar af leiðandi mun slíkt grunntilfelli ekki varna því að höfninni verði lokað í einhverjum tilfellum. Því mun heildstæð úttekt að öllum líkindum ekki leiða í ljós að dýpkunaraðgerðir einar og sér muni leiða til heilsársöfnunar hafnarinnar.

Vegvísir að heildstæðri óháðri úttekt

Við mat á mögulegum endurbótum á seinni stigum úttektar er gert ráð fyrir að beita þurfi aðferðafræði með samtvinnnaðri notkun fræðilegs mats, einfaldari reikninga og reiknilíkangerðar.

Leiðin að heildstæðri óháðri úttekt á Landeyjahöfn í samræmi við skilgreiningu Alþingis hefur verið kortlögð, með eftirfarandi nauðsynlegum næstu meginskrefum:

1. Úrbætur í upplýsingaöfluninni. Frekari gagnasöfnun og gagnagreining.
2. Skilgreining á grunntilfelli fyrir framtíðarrekstur hafnarinnar án endurbóta.
3. Ákvörðun á mögulegum endurbótum og mat á virkni þeirra.
4. Samanburður á mögulegum endurbótum með hliðsjón af spurningum þingsályktunarinnar.

Nánari grein er gerð fyrir þessum meginskrefum í skýrslunni. Frekari gagnasöfnun og gagnagreining er útlustuð og greint er frá helstu þáttum sem snúa að skilgreiningu grunntilfellis fyrir framtíðarrekstur hafnarinnar án endurbóta. Enn fremur eru dæmi tekin um hugsanlegar útfærslur endurbóta sem þarf að meta með hliðsjón af virkni. Er þar bæði horft til aðgerða til skjólmyndunar og lausna sem krefjast endurhönnunar á höfninni. Lagður er grunnur að hvernig samanburður verður gerður á mögulegum endurbótum.

Lokaorð

Með fyrstu skrefum í átt að heildstæðri úttekt á Landeyjahöfn hefur tekist að ná utan um helstu gögn sem höfninni tengjast og skilgreina helstu þætti sem upp á vantar og þarf að ráða bót á í úttektarferlinu. Enn fremur hefur tekist að skilgreina ferlið fram á við til mats á mögulegum leiðum til úrbóta á nýtni hafnarinnar. Það gefur fyrirheit um mögulega kosti að ferli loknu til grundvallar ákvarðanatöku um framtíðaráform fyrir samgöngubætur milli lands og Eyja.



1 Introduction

Landeyjahöfn harbour is a ferry harbour at Bakkafjara on the exposed south coast of Iceland. Its main purpose is to serve Herjólfur, a ferry that sails between mainland Iceland and the Westman Islands. Harbour construction started in August 2008. Since its opening in 2010 the harbour has suffered from severe sedimentation problems resulting in limited utilization of the harbour, especially during the winter months. Furthermore, navigation into the Landeyjahöfn harbour has been affected by severe wave climate, resulting in even further limitations in its utilization.

Dredging operations have been performed on a regular basis since opening of the harbour, although they have often been limited due to unfavourable marine conditions. Significantly more dredged material has been removed than was originally anticipated, resulting in high operational costs. The harbour has nevertheless experienced significant closures. Due to these long-term problems with keeping the harbour open for the ferry, the Icelandic Parliament issued a resolution in early December 2019 to the Minister of Transport and Local Government to commission an independent evaluation of the Landeyjahöfn harbour in accordance with current transport policy plans. The motion for the parliamentary resolution emphasized the importance of accelerating the review as the current situation at Landeyjahöfn harbour could not be considered acceptable for the inhabitants of Westman Islands or others who rely on the ferry. During the parliamentary process surrounding the motion, concerns were expressed on the navigational conditions near the harbour and it was stressed that all factors that may affect the utilization of the harbour should be included in the evaluation. Additionally, the motion requested that the following specific questions be addressed:

1. Is it possible to significantly decrease the frequency of dredging operations, or eliminate the need for dredging altogether, with improvement measures for the harbour?
2. If so, what would those improvement measures involve and what is their estimated cost?
3. If such improvement measures to the harbour are not deemed viable, either due to technical or financial reasons, then what type of dredging program would be necessary to eliminate closure of the harbour and keep it operational year-round?

In response to the parliamentary resolution, The Ministry of Transport and Local Government (hereafter referred to as “the Ministry”) defined a framework for an independent evaluation of Landeyjahöfn harbour utilization based on a data review and assessment process. The framework is based on a predetermined budget and timeline and confines the review and assessment process to a limited focus on available information relating to the harbour. The Ministry thus effectively defined a preliminary evaluation encompassing the first steps towards a comprehensive evaluation of Landeyjahöfn harbour which addresses as much as possible the goals of the parliamentary resolution and outlines further measures necessary to fulfil those goals. The framework takes into account uncertainties regarding the extent and availability of information needed for the review and assessment process. If further investigations are deemed necessary to meet the goals of the parliamentary resolution, those investigations will be performed separately as part of an ongoing process towards a comprehensive independent evaluation of Landeyjahöfn harbour.

The Ministry commissioned the independent evaluation through a public tendering process, and a consortium of three consulting firms, Icelandic firms Mannvit and Vatnaskil and Dutch firm LVRSConsultancy (hereafter referred to as the “consortium”), was awarded the tender. Mannvit is one of Iceland’s largest engineering consulting firms and has vast experience in various aspects of harbour development and operation. Vatnaskil is a consulting firm with nearly 40 years of experience in natural

resource management and environmental protection, including analysis and numerical modelling of processes related to surface-water hydrodynamics, wave climate, ocean currents and sediment transport in coastal areas. LVRIS-Consultancy is owned and operated by Dr. Leo C. van Rijn, one of the world's leading experts in coastal hydraulics and sedimentation. Dr. van Rijn has over 40 years of experience in solving various coastal sedimentation problems, including those related to harbour development on sand beaches.

In this report, the consortium presents a review of existing data made available for the evaluation. A general overview of the natural conditions affecting navigation in and around the Landeyjahöfn harbour is provided, followed by a review of data collected during pre- and post-construction periods. Information gaps identified during the data review process are presented, and additional data collection and analysis performed by the consortium in an effort to fill some of those gaps is described. An assessment of mitigation measures which have been implemented to date is summarized along with recommendations for identifying and assessing future improvement measures. The report concludes with presentation of a roadmap for further investigations needed to fully address the goals of the parliamentary resolution and thus lead to a comprehensive independent evaluation of the Landeyjahöfn harbour.

2 Review of available existing data

The Icelandic Road and Coastal Administration (IRCA) delivered a significant amount of data for the review of Landeyjahöfn harbour, including numerous reports and memos. In addition, other available data and documents were gathered from different sources. Overall, available measurement data appear to be of good quality and encompass most key natural processes affecting the conditions near the harbour. Reports and memos delivered by the IRCA are listed in Table 1. Pre-construction reporting accounts for the preparation and design phase of the harbour. Post-construction investigations have primarily been focused on sand transport and associated wave conditions, including seabed elevation changes and maintenance dredging.

Table 1. List of reports and memos handed over by the IRCA.

| Title | Institute/author | Date |
|---|------------------|----------------|
| A Ferry and Ferry Port on the Exposed South Coast of Iceland. A proposal for a practical solution for transport between Vestmannaeyjar and mainland Iceland | IRCA | June 2005 |
| Bakkafjara. Sediment Transport and Morphology, Phase 1. | DHI | January 2006 |
| Ferjuhöfn við Bakkafjöru. Áfangaskýrsla um rannsóknir og tillögur. | IRCA | February 2006 |
| Bakkafjara. Sediment Transport and Morphology, Phase 2. Final Report. | DHI | August 2007 |
| Greinagerð vegna blaðaskrifa Sveins Rúnars Valgeirssonar um rannsóknir vegna ferjulægis á Bakkafjöru | IRCA | 2008 |
| Bakkafjara. Wave set-up and erosion depth along breakwaters. | DHI | February 2008 |
| Bakkafjara. Breakwater configuration. | DHI | March 2008 |
| Bakkafjara. Technical Note on the Development during Autumn 2010. | DHI | December 2010 |
| Rannsóknir á sandi úr Landeyjahöfn – Niðurstaða prófana | Efla | August 2012 |
| Comments on the revised investigations performed by DHI regarding Landeyjahöfn harbor | Lund University | February 2013 |
| TVRL comments on the revised DHI report 11812013_LANDEYJAHÖFN_15.02.13_PART regarding Landeyjahöfn harbor | Lund University | February 2013 |
| Landeyjahöfn. Further investigations. Additional analysis and modelling. | DHI | September 2013 |
| Minnisblað – Öldufar við Markarfljótsósa | IRCA | October 2013 |
| Technical Memo – Sand transport in Landeyjahöfn, Volume calculations. | IRCA | February 2015 |
| Technical Memo – Waves outside Landeyjahöfn | IRCA | April 2015 |
| Minnisblað – Ytri garðar við Landeyjahöfn | IRCA | April 2015 |
| Minnisblað – Öldugögn fyrir Landeyjahöfn. Viðbót 2010 – 2014 | IRCA | June 2015 |
| Technical Memo – Detacked Breakwaters outside Landeyjahöfn | IRCA | August 2015 |

| | | |
|--|------------------------------|---------------|
| Technical memo – Landeyjahöfn. Comparison between the directional Waverider buoy, MIKE21 SW, the Bakkafjara east buoy and the radar. | IRCA | November 2015 |
| Minnisblað – Landeyjahöfn ytri garðar. MIKE21 SW keyrslur fyrir Landeyjahöfn með og án ytri garða. | IRCA | February 2016 |
| Landeyjahöfn maintenance dredging | Van 't Hoff Consultancy | June 2016 |
| Siltation Problems at the Landeyjahöfn Harbour, Iceland. Governing Processes and Coastal Evolution. | Lund University | July 2016 |
| Minnisblað – Landeyjahöfn. Samanburður á stefnudufli og MIKE21 SW reikningum. | IRCA | November 2016 |
| Minnisblað – Dýptarbreytingar í Landeyjahöfn vetur 2015-16. Viðhaldsdýpkun í Landeyjahöfn | IRCA | February 2017 |
| Minnisblað – Dýptarbreytingar í Landeyjahöfn vetur 2016-17. Viðhaldsdýpkun í Landeyjahöfn | IRCA | February 2017 |
| Technical Memo – Landeyjahöfn. Evaluation of return periods of significant wave height and sea level. | IRCA | November 2017 |
| Seljalandsheiðarnáma, E-422 - Efnistaka vegna endurbóta á Landeyjahöfn í Rangárþingi eystra. Kynning á efnistöku - á vegum Vegagerðarinnar | IRCA | January 2018 |
| Landeyjahöfn structures | Van der Meer Consulting B.V. | January 2018 |
| Influence of modified breakwater heads on the sediment transport and deposition at Landeyjahöfn, Iceland | Lund University | February 2018 |
| Sedimentation in entrance of Landeyjahöfn. Assessment of proposed land based dredging system. Impact on the littoral drift and the transport and settling of sand. | DHI | February 2018 |
| Memo – Sediment grain size at Landeyjahöfn 2015-2018 | IRCA | August 2018 |
| Memo – Timeseries of seabed elevation in Landeyjahöfn in the period 2016-18. Timeseries of bed elevation at eight locations in Landeyjahöfn harbour. | IRCA | October 2018 |
| Memo – Dredging activities in Landeyjahöfn 2018 | IRCA | January 2019 |
| Memo – Dredging activities in Landeyjahöfn 2017 | IRCA | March 2019 |
| Hydrodynamic numerical model of waves and currents at Landeyjahöfn Harbour | University of Iceland | May 2019 |
| Landeyjahöfn rúmmálsbreytingar 2002-2020 | IRCA | May 2020 |

The IRCA provided an extensive set of maps and documents containing information on measured bathymetries for the years 2002 to 2020, particularly in relation to dredging operations and associated difference maps resulting from dredging activities. All maps are given in metres to chart datum (CD), which is about 1.45 m below mean sea level. The majority of maps produced before 2009 were relatively large scale, showing bathymetry over an area extending approximately 7 km west and 5 km

east of the harbour location and extending 2 km from the coastline. Maps produced since 2009 are on multiple scales, usually covering a frame of about 1 km in width, centred on the harbour and extending about 1.4 km south from the harbour. Some of the smaller scale maps are full surveys but many are surveys that were made before and after dredging operations to quantify the volume dredged and are therefore limited in coverage area. A list of dates of available bathymetric surveys was compiled during the evaluation process and is shown graphically in Figure 1. Furthermore, the IRCA provided reports, summaries and data sheets relating to sediment grain size analyses. Grain size samples were taken at various times both pre- and post-construction in the harbour and its vicinity.

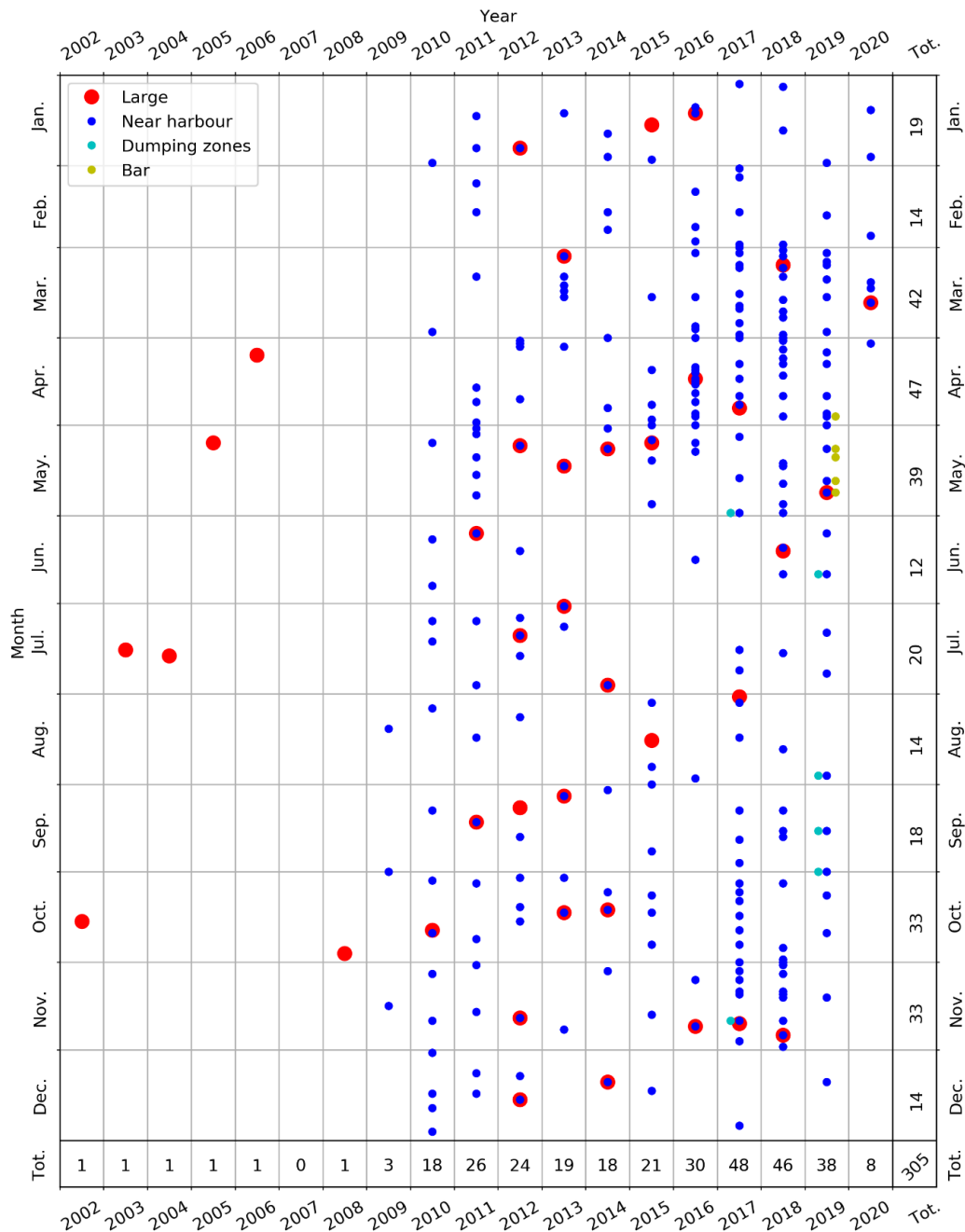

Figure 1. Dates of available bathymetric surveys shown as points. Red points show surveys over a large area, blue points show surveys in the vicinity of the harbour, cyan points show specific surveys of dumping zones and yellow points show specific surveys of the outer bar. Total number of surveys are shown for months and years under the Tot. column and row respectively.

IRCA handed over graphs and timeseries data from a directional buoy located in the vicinity of the Landeyjahöfn harbour. Data from the buoy covered a period from August 2015 until late February 2020. In 2003 the first Waverider buoy (BFD1) was deployed and it recorded data until it was deactivated in 2013. In 2010 the second buoy (BFD2) was installed and was later deactivated in 2015. Both BFD buoys recorded non-directional measurements at approximately 30 m water depth. In September 2015 a new directional wave rider buoy (BFK) was installed west of BFD2 (eastern buoy). Operating times and locations for each of the buoys are shown in Figure 4. The non-directional wave data were requested but not delivered.

Timeseries of measured tidal elevation at Landeyjahöfn harbour from late October 2010 to September 2019 were delivered by the IRCA. This data was provided both in the form of raw data and as graphs.

The IRCA provided images (in gif format) of data from a radar station located at the harbour. The images show wave direction and surface current in the vicinity of the harbour. Additional timeseries (as images and text files) of wave and wind driven surface current velocity and direction extracted from the radar dataset for most of May and June 2020, were also made available by the IRCA. Additional data was requested for the time period October 2019 – April 2020 but it was not delivered.

According to the IRCA, the radar data has not been calibrated, and has mostly been used to indicate the real-time wave height close to the mouth of the harbour for the ferry captains to use for navigational purposes.

The IRCA delivered weather data from the weather station at the Landeyjahöfn harbour for the period September 2010 to September 2019. Additional weather data were handed over by the Icelandic Meteorological Office (IMO) upon request for 7 other weather stations located in a 30 km radius around the harbour (IMO, 2020a, 2020b, 2020c, 2020d, 2020e, 2020f). All data from the IMO included at least 10 years of measurements.

Footage from a CCTV camera located at the harbour were also handed over by the IRCA. The provided footage covered various time periods during the years 2018 and 2019.

A general review of available reports and memos collected for the evaluation reveals that the main focus of the measurement and data collection program implemented at the harbour to date has been on sedimentation and assessing post-construction dredging mitigation measures. A total of 7 reports, articles and memos were handed over regarding the pre-construction phase of the harbour, all of which were produced by the IRCA (at that time the Icelandic Maritime Administration, IMA) and DHI. Additional reports were collected from other sources, including a report which was produced for the IRCA during the environmental impact assessment phase of the harbour project (VSÓ ráðgjöf, 2008). The pre-construction results are summarized to a great extent in one IRCA report (IRCA, 2006) and two DHI reports containing detailed morphology studies (DHI, 2006; 2007). The pre-construction hydro-morphodynamic and other supporting studies are discussed further in Chapter 2.2.

Soon after the opening of the harbour in 2010, sedimentation problems became evident. A large sediment load from the nearby river Markarfljót in response to a sub-glacial volcanic eruption in April of 2010 was thought to be the reason. Later that year DHI wrote a technical note on the sedimentation situation (DHI, 2010). Three years later, DHI published an additional extensive analysis including modelling of Landeyjahöfn, where measures were suggested to mitigate increased sedimentation in the harbour (DHI, 2013). At the time, no re-evaluation of the sedimentation rate, estimated during the design phase of the harbour, was made as DHI believed that it was unclear whether the increased sedimentation was in fact due to the volcanic eruption. In the following years, the IRCA and DHI

published memos on sedimentation and further analyses on potential mitigating solutions for the increased sedimentation. These mitigation measures included a land-based dredging solution and detached breakwaters outside the harbour on the outer bar located about 1 km offshore. Post-construction hydro-morphodynamic and other supporting studies are discussed further in Chapter 2.3.

An assessment on longshore transport and sedimentation values in the vicinity of the harbour has been made by the consortium as part of the present evaluation. The assessment is based on computations using fairly simple models and data from preliminary wave analysis as well as basic bathymetric analysis, and is provided in Chapter 3. Assessment of data relating to historical maintenance dredging is provided in Chapter 4.

2.1 Site conditions at Landeyjahöfn harbour

The area surrounding the harbour is characterized by black beach sands (basalt sand), often experiencing harsh weather conditions and high offshore waves that can reach heights of nearly 25 m (with wave heights of 16.4 m for 100 year return period, offshore region) (DHI, 2007) and significant sand transport. Markarfljót, a dynamic glacial fed river with pronounced meandering and braiding, is situated roughly 2.5 km east of the harbour. Discharge from the river is extremely variable, ranging from about 100 to 1000 m³/s (not accounting for extreme events) and 100,000-200,000 m³ of sand is transported out to sea annually according to DHI reports (DHI, 2006; 2007; 2013). Historical observations show that the location of the river mouth is moving in what seems to be a cyclical pattern, moving east to west and back over a few kilometres of coastline in about 40 years (Viggosson, Jónsdóttir, Sigurðarson, & Bernódusson, 2005). The river mouth consists of a marked delta protruding into the sea. The delta sand is redistributed by the waves, often in the form of a spit where the wave direction determines whether the sand in the delta is pushed to the east or to the west. If the supply is large, the spit can grow extensively during events with waves coming from the southeast.

2.1.1 Weather, waves and currents

Weather

The weather station at Landeyjahöfn harbour is located at one of the breakwaters inside the harbour. Last year the weather station was temporarily relocated within the harbour due to maintenance and changes that were made on the breakwater where the weather station was located. The weather station has been in operation since late 2010 and records wind speed and direction, air temperature and air pressure.

The average windspeed recorded at the Landeyjahöfn weather station is 7.0 m/s over the period September 2010 to September 2019. The maximum windspeed is about 33 m/s but about 99.5% of the time the windspeed is below 22 m/s, which is the maximum windspeed the new Herjólfur ferry is designed for. The most common wind directions are east and east-south-east (see wind rose, Figure 2) which are also the most common storm directions. Southern wind directions are more common than northern directions.

The average temperature at Landeyjahöfn is 6 °C but during winter months the temperature can go below -10 °C and in summer months it can occasionally rise above 20 °C.

The wind rose at Landeyjahöfn harbour shows similar wind direction frequencies as an offshore wind rose from the Stórhöfði weather station on the Westman Islands, although the offshore station has much higher windspeeds (Figure 3). The west to north sector of the wind rose at Landeyjahöfn harbour

is more frequent compared to the wind rose at Stórhöfði for the same time period (2010-2019). The relatively frequent northwest direction at Landeyjahöfn is not observed in other neighbouring on-land weather stations (IMO, 2020a, 2020b, 2020c, 2020d, 2020e, 2020f).

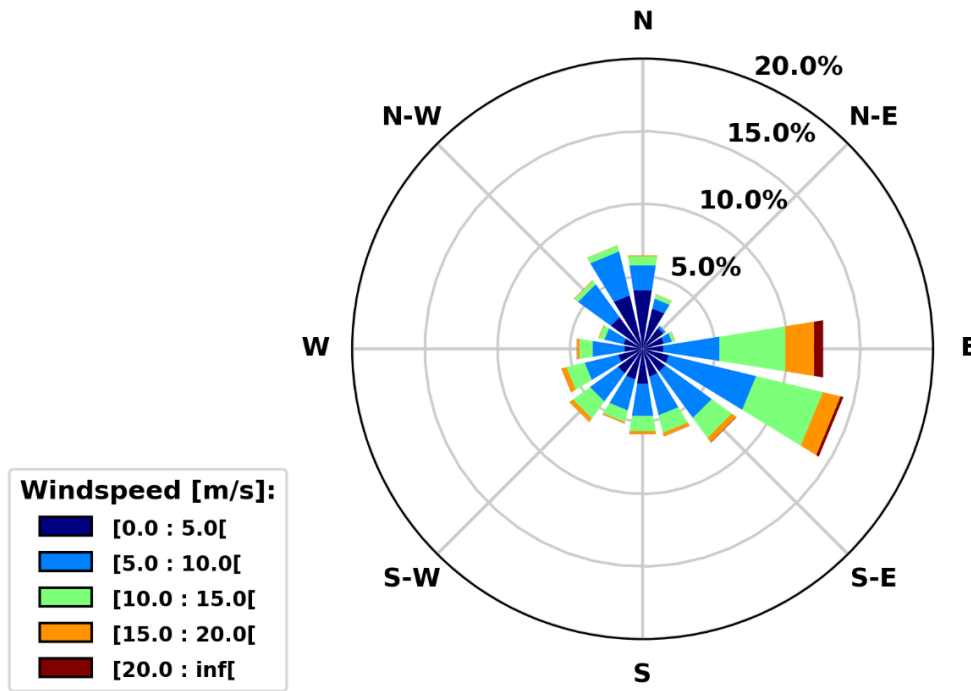

Figure 2. Wind rose for Landeyjahöfn harbour weather station.

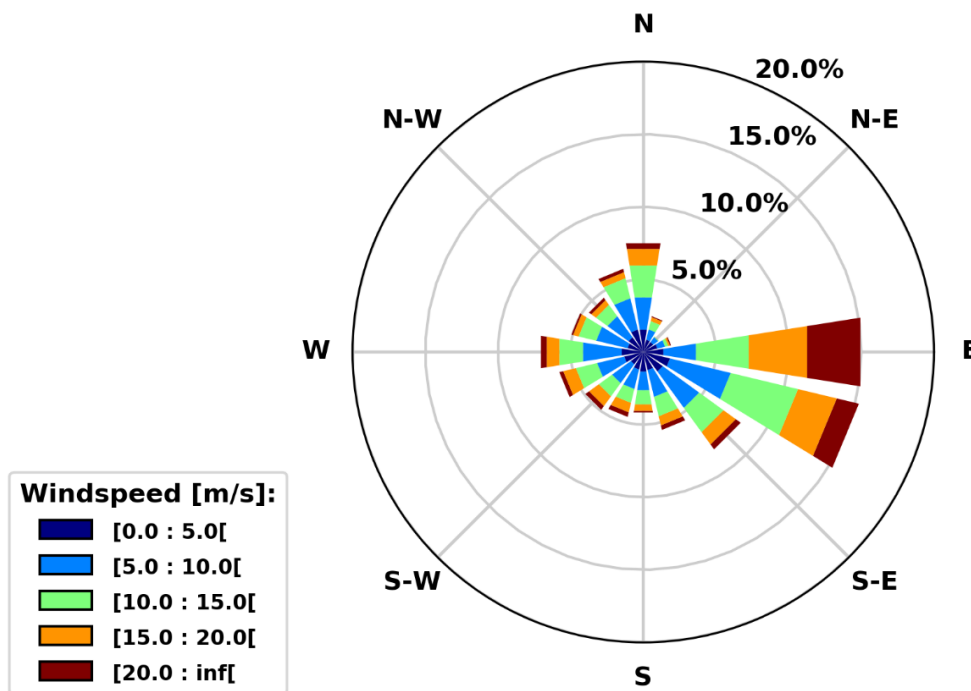

Figure 3. Offshore wind rose from Stórhöfði, located about 30 km south-south-west of Landeyjahöfn.

Tides

The tidal data shows a springtide of about 3 m and neap tide of about 1 m. According to information from the Icelandic Transport Authority's (ITA) website, current measurements have been attempted with regards to informing seafarers in real-time on the velocity and direction of the current near the harbour. Due to high sediment transport and harsh conditions outside the harbour these attempts have not been successful except for the surface currents calculated by the radar station at the Landeyjahöfn harbour (ITA, 2012). Measured estimates of the tidal component of the currents are not available. However, numerical models have been used to estimate the tidal current, both by DHI and IRCA (then Icelandic Maritime Administration, IMA). Estimated peak tidal currents at offshore depths of 10 m are in the range of 0.1 m/s during neap tide to about 0.4 m/s during spring tide (DHI, 2007). The tidal current velocity could be confirmed with measurements during periods of calm winds.

Waves

Offshore wave data have been recorded since 1988 at the Surtsey wave buoy located south of the Westman Islands at an ocean depth of 130 m (Viggosson, Jónsdóttir, Sigurðarson, & Bernódusson, 2005). Additionally, three wave buoys have been used in the vicinity of Landeyjahöfn harbour since 2003 at locations with ocean depth around 30 m. Locations of the buoys are shown in Figure 4. At first, non-directional wave data were recorded, but since 2015 measurements have been performed at a directional buoy and the non-directional measurements have been discontinued. Wave analysis, based on a numerical model covering the period 1979 to 2004, show that waves from the direction south to west are dominant (12% from southeast; 30% from south; 42% from southwest and 17% from west) (DHI, 2007), see Figure 5. Extreme wave data from two buoys are given in Table 2.

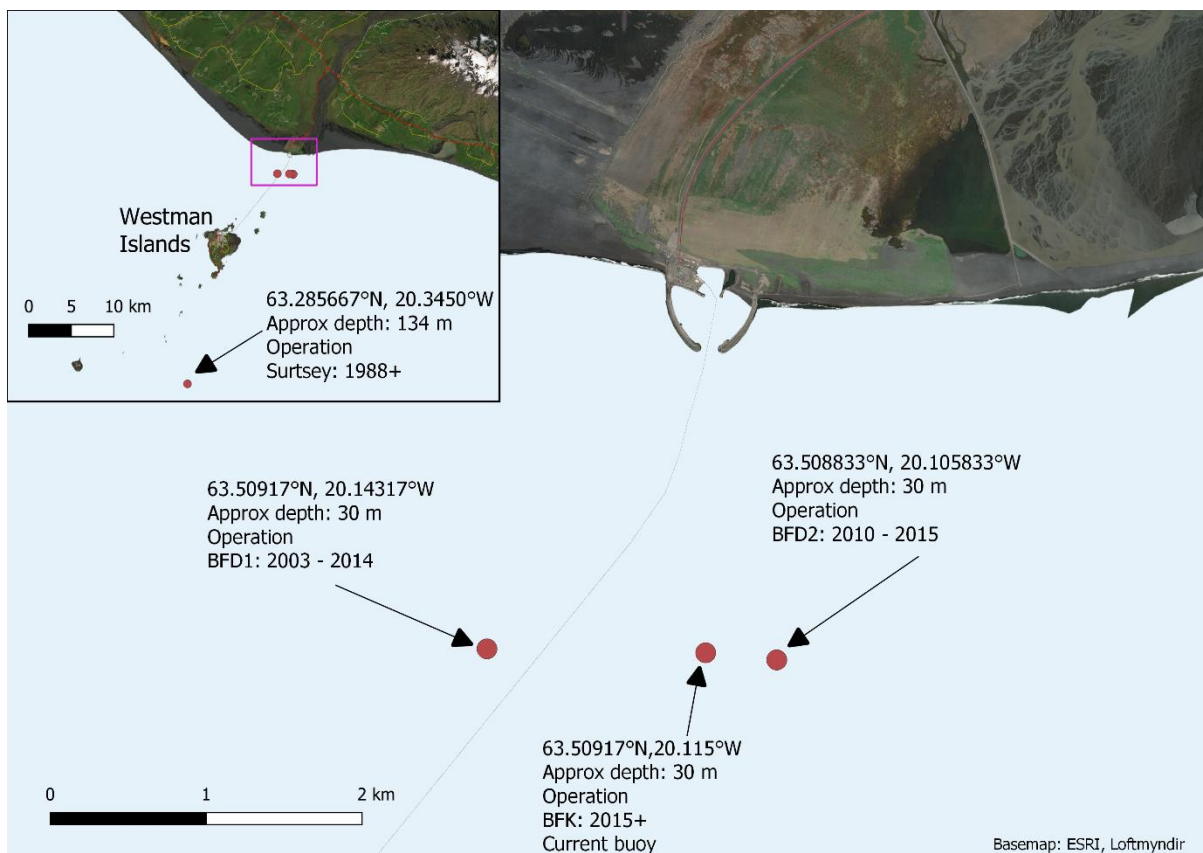

Figure 4. Location of wave buoys and their operational periods.

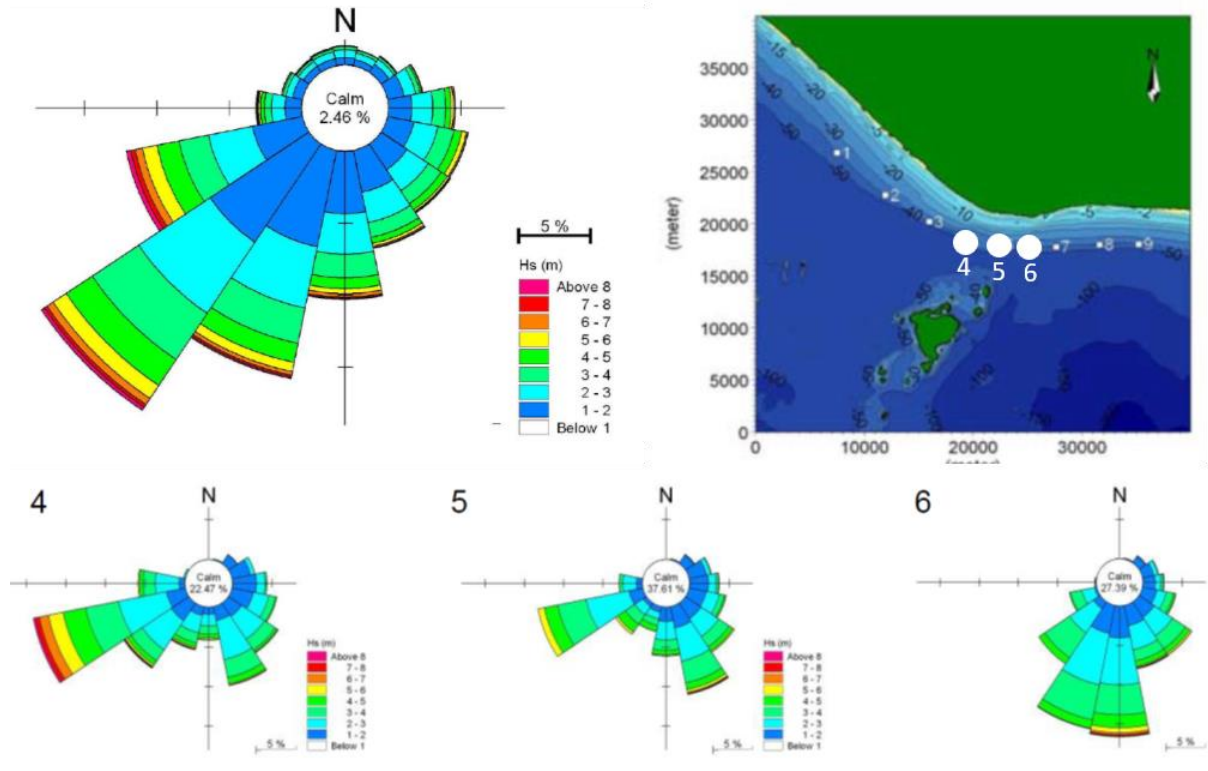

Figure 5. Offshore wave rose (left upper) and nearshore wave roses (lower) (DHI, 2006; DHI, 2007). Stations 4,5 and 6 are indicated on the map with white dots.

Table 2. Results of a Weibull extrapolation of statistical analysis for measured buoy data for Surtsey data (1988 – 2004) and Bakkafjara data (November 2003 to March 2005, buoy BFD1, see Figure 4) (Viggosson, Jónsdóttir, Sigurðarson, & Bernódusson, 2005).

| Return period (years) | Wave buoy west of Landeyjahöfn harbour location (depth 30 m) | | Surtsey wave buoy offshore Westman Islands (depth 130 m) | |
|--------------------------|---|--------------------|---|--------------------|
| | H _s (m) | T _p (s) | H _s (m) | T _p (s) |
| 1 | 6.8 | 16 | 11.7 | 16 |
| 10 | 7.7 | 18 | 14.1 | 18 |
| 100 | 8.5 | 20 | 16.4 | 20 |

Wave refraction effects for various wave directions at the Bakkafjara Coast are shown in Figure 6 (Viggosson, Jónsdóttir, Sigurðarson, & Bernódusson, 2005). The arrows show wave direction and wave height is indicated by contour lines, with wave height decreasing with darker shades of blue. The data indicates wave sheltering effects occurring in the sector 180° to 230°. In this report, all wave directions are given as the direction from which the wave is coming in degrees from north, clockwise. North is therefore defined as 0°, east as 90°, south as 180° and west as 270°.

DHI has used a wave transformation model to derive wave data at a nearshore depth of 40 m (Figure 5). The sheltering effect of the Westman Islands can be clearly seen in the nearshore locations 4, 5 (near harbour location) and 6, where the waves from the sector south-southwest are substantially reduced.

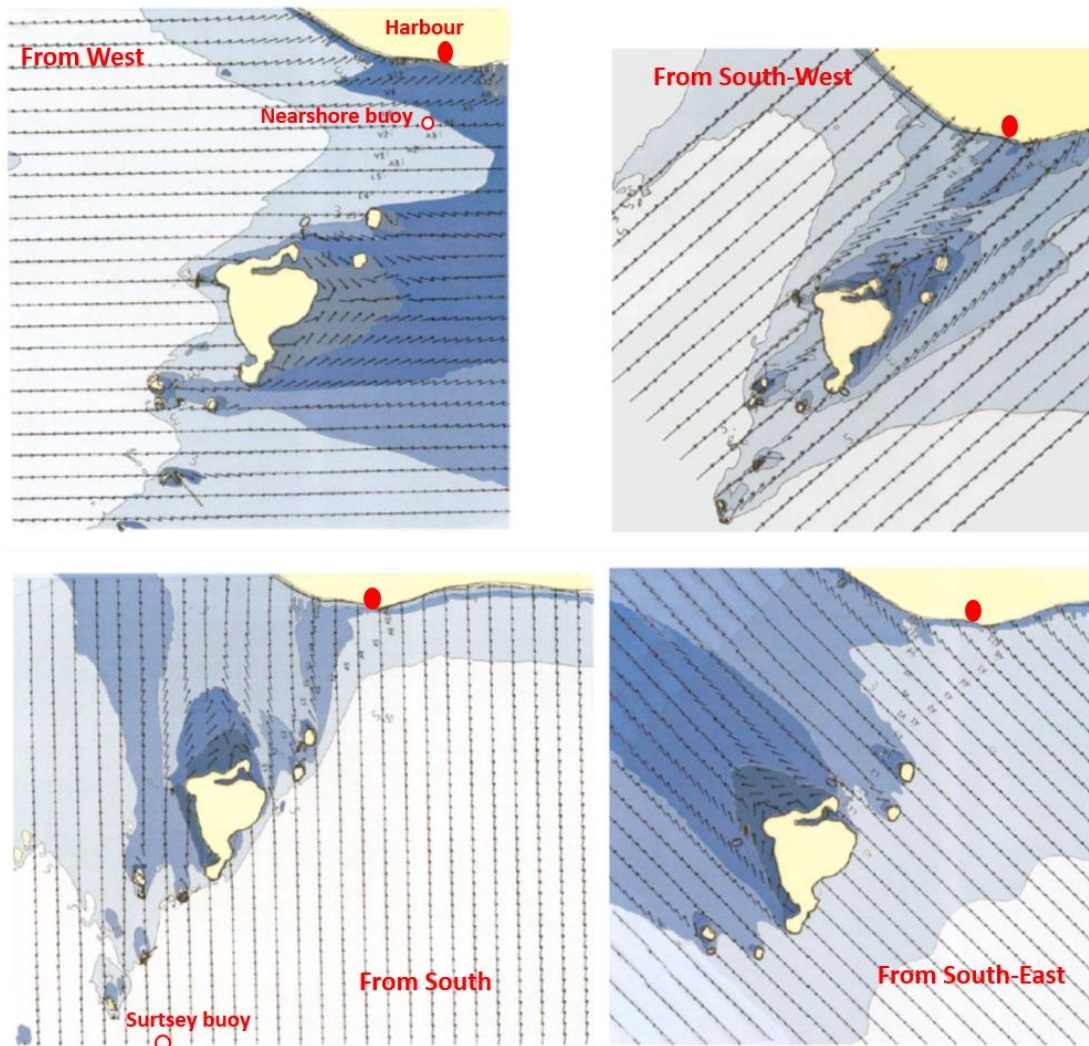

Figure 6. Wave propagation from 4 directions towards harbour location (Viggosson, Jónsdóttir, Sigurðarson, & Bernódusson, 2005).

DHI has summarized the 20 most severe storms based on modelled data for the period 1979 to 2004 (DHI, 2006; DHI, 2007; DHI, 2013). In nearly every year, a major storm did occur with mean significant wave height in the range of 8 to 12 m (and peak periods in the range of 12 to 15 s) and duration in the range of 24 to 60 hours. Almost all storms came from the sector 180° to 270° (southwest). Only one storm came from the direction 135° to 180° (southeast).

Almost all wave analysis studies that have been performed by DHI or the IRCA have focused on analysing modelled data or comparing measured data to results from numerical models. A detailed wave climate analysis based on the directional wave data itself is not available. This type of detailed analysis would be of great value and is considered essential information needed to properly address the questions put forth in the parliamentary motion. The consortium therefore suggested to perform such an analysis parallel to the present evaluation. This work would have expanded the predefined scope of the evaluation framework, however. Therefore, the Ministry decided not to proceed with the additional analysis at this stage in the evaluation process. However, in order to provide an estimate of longshore sediment transport rates and an assessment on deposition volumes, the consortium performed a limited, preliminary analysis of available measured directional wave data during the present evaluation. This analysis is discussed further in Chapter 3.

In June 2013, a radar station indicating various wave and surface current parameters was installed inside the harbour area. The station has been in operation since then, recording measurements every 2 minutes. The radar data is, however, yet to be calibrated. Measurements based on data from June 2013 – July 2014 were reported by the IRCA (2015e). When wave height is between 2 and 2.5 m the current velocity at the surface in front of the harbour entrance is about 0.7 ± 0.5 m/s with two peaks with direction around 120° (westward) and 260° (eastward). When wave heights are in the range 2.5 to 5 m, the surface current velocity increases to about 1.2 ± 0.8 m/s with two peaks with direction around 110° (westward) and 260° (eastward). This measured surface velocity is much higher than the previously discussed modelled peak tidal current of 0.1-0.4 m/s (DHI, 2007), suggesting that the surface current velocity in front of the harbour mouth is dominated by wind driven and wave driven currents. A proper analysis has not been performed on this data, and other factors such as local wind effects have not been taken into account to date.

Extrapolation of data series over 3 years (IRCA,2017c) using the Weibull method yields a 1-year return period of $H_s = 5.8$ m (over 1 hour) and $H_{max} = 9$ m. This is significantly lower than the 6.8 m for the wave buoy west of Landeyjahöfn harbour (Table 2). The 10-year return period from the radar is $H_s = 6.2$ m (over 1 hour) with $H_{max} = 9.6$ m and 100-year return period of $H_s = 6.5$ m (over 1 hour) and $H_{max} = 10$ m. This uncalibrated radar data suggests that there is a significant reduction in the wave height between the buoy at about 30 m depth and the harbour entrance. The radar shows highest waves occurring at sea levels in the range of 2.4 to 3 m above CD. Further analysis could be performed, which would benefit from using calibrated radar data.

2.1.2 Sediments and bathymetry

Sediment samples were collected in 2006 on the sandy Landeyjasandur beach as well as along multiple lines perpendicular to the coastline over a 6 km distance along the coastline in the vicinity of the proposed harbour. A total of 126 samples were collected in the 2006 study. As reported by DHI (DHI, 2007), sand is found to be finer (0.15 mm) offshore of the outer sand bar and in the trough and coarser (0.3 to 0.45 mm) on the bar crest and near the beach. The mean grain size varies between 0.15 mm and 0.45 mm. The average size is 0.25 mm. The density of basalt sand is about 2850 kg/m^3 . Other post-construction surveys have been performed as well on sediments in the area. Surveys from 2006 and 2012 indicate that there is roughly the same distribution of sediment grain size in the area while a survey from 2011 indicates large amounts of fine sediment likely from the volcanic eruption of Eyjafjallajökull in April 2010 (DHI,2013). An analysis on the sediment grain size at Landeyjahöfn harbour from four surveys performed between 2015-2018 (IRCA, 2018c) showed a significant temporal and spatial variation in sediment gradation. The causes of the variation are not fully understood. It was recommended by the IRCA (2018c) that sediment samples would be taken at regular time intervals, e.g. monthly for one year, to determine seasonal variations and other factors which contribute to variations in grain sizes around the harbour.

The river delta is most pronounced in the spring and summer period when the river discharge is fairly high, and waves are fairly low. The average river discharge of sand is estimated to be about $100,000 \text{ m}^3/\text{year}$, whereas the discharge of fine sediments (silt/mud) is much higher at about $1 \text{ million m}^3/\text{year}$ (DHI, 2007). The fines are spread over a very large area and do not interact with the local sandy morphology (DHI, 2007).

According to the delivered bathymetric data and related information from the IRCA, only a limited effort has been made to analyse the bathymetry data for the purpose of obtaining sedimentation patterns. However, basic information has been extracted to support the maintenance dredging



activities. Elevation difference has been calculated between some of the bathymetry surveys and rough estimates of deposition rates have been made based on elevation differences and time between surveys. No proper analysis of deposition patterns and volumes as a function of space and time has been performed.

Three documents are available that show limited analysis of volume changes based on the bathymetric surveys. One document shows rough volume changes in comparison to a bathymetry survey from March 2020 (IRCA 2020) within a large area extending 1 km east and west of the harbour and from about 1.5 km offshore to an ocean depth of roughly 15 m. This volume change data is available every other year over the period 2002 – 2020. The other two documents show volume changes in different zones for the periods August 2015 – August 2016 (IRCA,2017a) and August 2016 – February 2017 (IRCA,2017b).

A suitable analysis of the bathymetry maps indicating prevailing deposition patterns and volumes as a function of space and time has not been performed to date. Such detailed analysis is considered essential information needed to properly address the questions put forth in the parliamentary motion. The consortium therefore suggested to perform initial steps towards such an analysis parallel to the present evaluation in order to accelerate the process towards a complete, comprehensive evaluation of the Landeyjahöfn harbour. However, due to the fact that this additional work would have expanded the predefined scope of the evaluation framework, the Ministry decided to wait with the analysis until a later stage in the overall evaluation process.

Two typical bathymetries from pre-construction bathymetric surveys are shown in Figure 7. Typical features of the bathymetry in the area are a bar-trough system with a bar crest at 4 to 8 m depth and trough depth around 8 to 12 m on the west side of the harbour location, with local bar depressions for outflow of rip currents. The water depth in the depression at the location of the harbour varies in the range of 6 to 8 m with a cycle time of about 5 to 10 years (based on data prior to 2006). An outer bar crest is at about 0.8 to 1.2 km from shoreline with a typical bed slope around 1 to 75 on the seaward flank of the outer bar and around 1 to 40 on the landward flank. Bed slope of the beach face down to the bar trough at 10 m depth is about 1 to 100. On the east side of the harbour location is a river delta with attached spit system on its west side.

Analysis performed by DHI of the available bathymetry data prior to the construction of the harbour showed that a bar depression was present at the location of the harbour (DHI, 2007). During some periods, the growth of a spit formation from the delta of the river mouth can be observed in the data. This spit was, at the time, growing towards the west, however it was not observed to have reached the location of the harbour. The strongest westward spit migration was observed in 1986 and the maximum amount of accumulation was about 500,000 m³. Assuming a spit volume of approximately 1250 m³/m, this corresponds to a migration distance of 400 m. It is noted that the events with westward transport and spit growth have typically been followed by periods of eastward transport. The growth of the spit is not only limited by the transport capacity towards the west but also by the limited source of sand in the delta.

The most significant bar crest migration to the east was in 1990 with an eastward transport of about 170,000 m³. With a volume in the outer bar of approximately 1250 m³/m, this corresponds to an eastward bar migration of about 140 m (DHI, 2007; DHI, 2006).

The spit is often removed (eroded) during winter periods with high waves. In addition, the outer bar system may be interrupted locally (depression) due to the generation of local rip currents. Such an

interruption is often present at the harbour location, where a major outgoing flow pattern may occur as part of flow passing around the river delta.

Typical cross-shore profiles are shown in Figure 8. Profiles 1 to 5 include a distinct bar with a crest level between 5 and 6 m while the profiles 6 to 9 do not include an offshore bar.

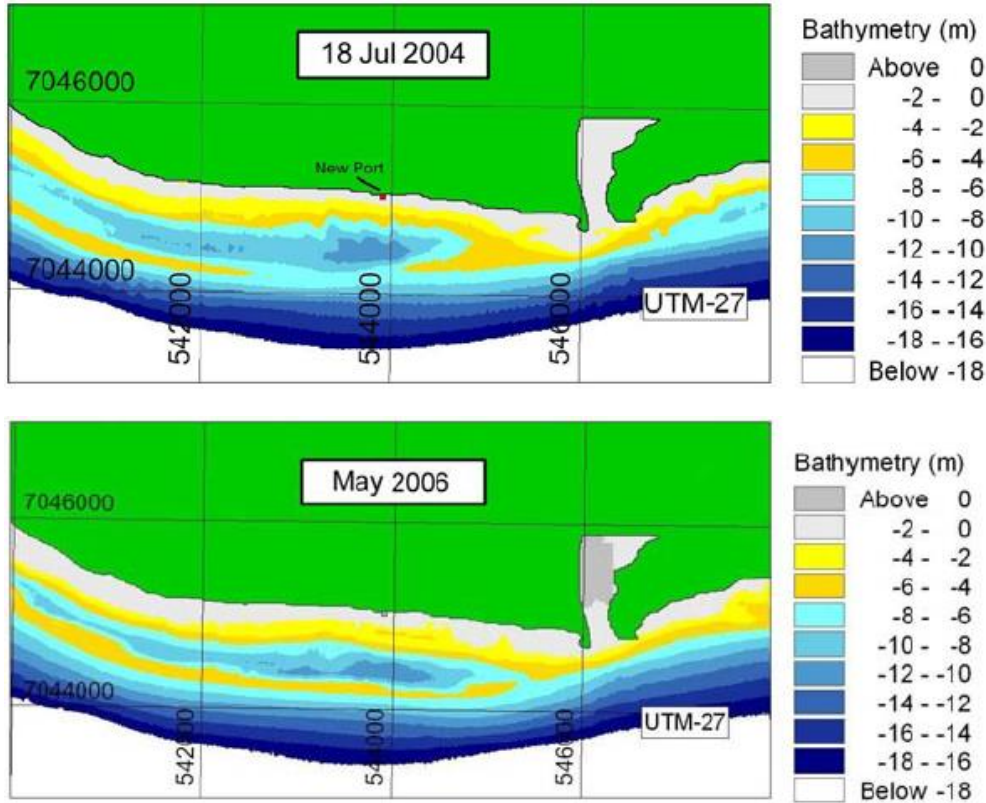

Figure 7. Bathymetry in July 2004 and May 2006 (DHI, 2007).

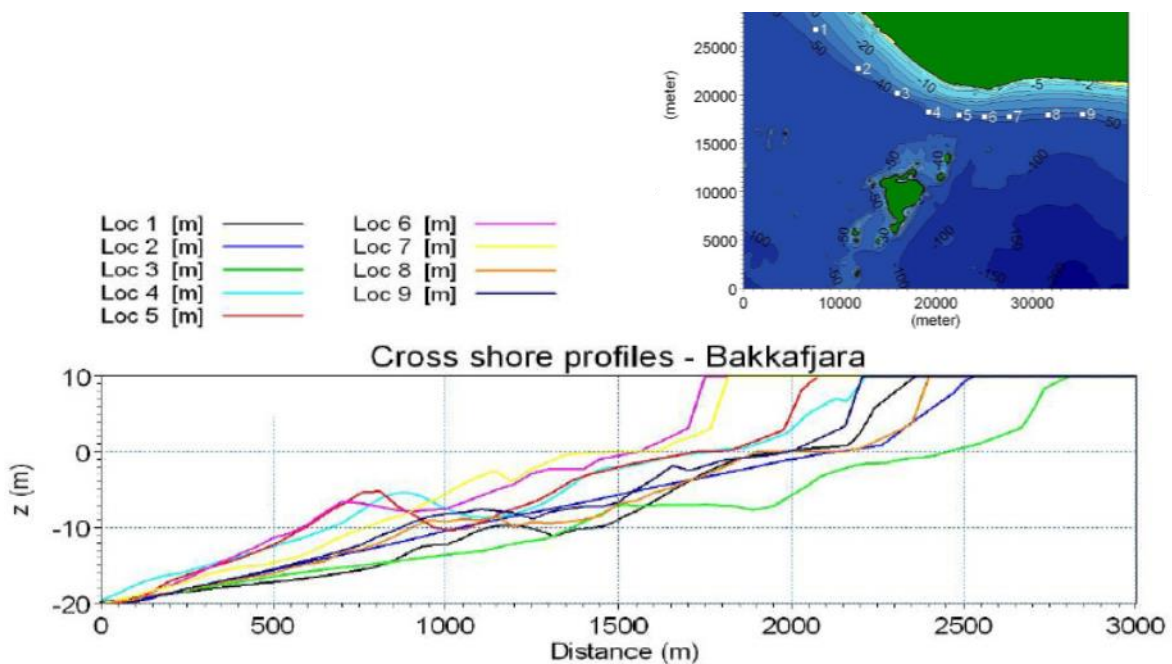

Figure 8. Typical cross-shore profiles (DHI, 2006).

2.1.3 Navigational conditions

The landing pier for the Landeyjahöfn ferry is situated inside the harbour basin, at an angle to the main navigational line inside the harbour in order to shelter it from waves entering the harbour mouth during southern wave directions. The harbour basin is formed by two curved breakwaters about 500 m long extending from the shoreline to about 7-8 m depth, allowing for a roughly 90 m wide entrance to the harbour basin. When the ferry approaches the harbour, it must navigate through an opening in the outer bar and onward towards the relatively narrow harbour entrance.

With movement of the bar crest and high sand deposition rates observed in the harbour, navigational conditions are greatly dependent on a combination of weather conditions, waves, sedimentary deposits on the sea bottom, harbour design and construction, and design and physical characteristics of the ferry vessel itself. The ferry captains must therefore evaluate at any given time if any or all of these conditions may limit safe navigational conditions. A further discussion is provided on the navigational conditions in Chapter 4.1, with respect to a review of available documentation and resulting assessment on the dependent factors.

2.2 Pre-construction hydro-morphodynamic studies

DHI (DHI, 2006; DHI, 2007) produced 2 technical reports focused on the design aspect of the proposed harbour, termed Bakkafjara harbour at that time. The items studied by DHI were:

- annual waves, extreme storm waves and currents;
- historical shorelines, longshore transport rates and overall sediment budget;
- morphological behaviour of the outer bar;
- equilibrium water depth in front of the harbour entrance;
- shoreline morphology around the harbour;
- sedimentation inside the harbour basin.

This chapter summarizes the main topics and findings of the DHI technical reports focusing on the design aspect of the harbour.

2.2.1 Annual waves, extreme storm waves and currents

Waves

The modelling of waves and flow were performed with the coupled MIKE 21 FM model. The model calculates waves (MIKE 21SW; fully spectral wave model, excluding wave diffraction) and tidal flow (MIKE 21 HD) on an unstructured mesh and in a sequential and fully integrated manner. The model bathymetry was derived from water depths obtained during the bathymetrical survey of May 2006. Near the harbour, the resolution of the bathymetry was increased to about 5 m to represent the bar-trough structure.

The harbour breakwaters were implemented as streamlined breakwaters with the entrance facing south. The width of the entrance (between the feet of the two breakwaters) was 100 m and the entrance was located at an undisturbed water depth of 8.0 m. The presence of the Westman Islands was expected to cause some of the incident wave energy to be diffracted, but this effect was found to be of minor importance.

The combined regional wave transformation model and local wave model were validated against measured waves in March 2004 from the Bakkafjara wave buoy (BFD1, see Figure 4) (only wave heights, no directions), deployed November 18, 2003 at a location west of the proposed Bakkafjara harbour at a depth of 28 m.

Figure 9 shows computed wave heights and patterns for a storm from the southwest. Wave sheltering occurs in the lee zone of the Westman islands. Wave refraction can be clearly observed. Nearshore waves close to the harbour entrance are about 3.5 m during the storm event. Figure 5 shows the computed wave roses based on the mean long-term offshore wave climate.

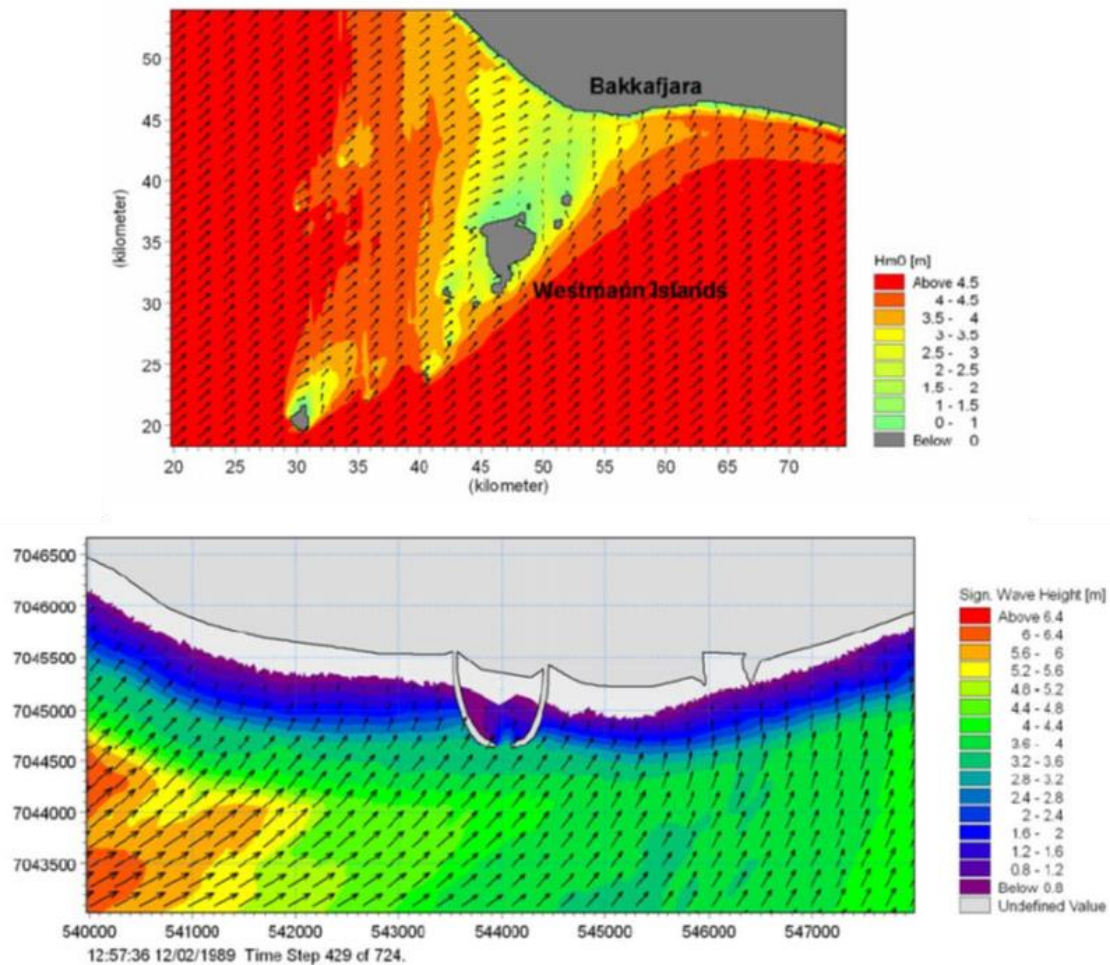

Figure 9. Computed wave heights and patterns for storm from southwest (DHI, 2007).

Currents

DHI's hydrodynamic model MIKE 21HD (used in 2DH-mode) was used to simulate the flow using depth integrated formulations (2D flow equations). The model includes all driving forces and phenomena that are important for flow in the nearshore zone such as Coriolis force, tides, storm surge, wave forcing (radiation stress), wind forcing, momentum dispersion and bed friction. Discharge from the river Markarfljót located approximately 2.5 km east of Bakkafjara was included in the hydrodynamical setup (about 100 m³/s; peak value up to 160 m³/s).

Figure 10 shows computed tidal elevations and currents for a water depth of 10 m. Tidal currents are up to 0.4 m/s.

Figure 11 shows current patterns for tidal flow in combination with waves. Model results show that typical current velocities near the harbour entrance are:

- 0.3 to 0.4 m/s to the west generated by waves from the south;
- 0.9 to 1.2 m/s to the east generated by waves from the southwest.

Model results of wave heights and current velocities along a line normal to the harbour entrance (navigation line) during storm events are given in Figures 12 and 13. The wave height during the peak of a storm in 1985 decreases by about 30% from location 4 to location 2. For comparison, the current buoy BFK (Figure 4) is about 1.4 km south of location 4.

The current velocities seaward of the outer breaker bar are tide- and wind-generated generated with values in the range of 0.5 to 1 m/s. Tidal velocities are lower in shallow water due to bed friction. The current velocities landward of the outer breaker bar are wave-induced longshore current velocities with values up to 1.7 m/s depending on the wave incidence angle. The values at the harbour entrance are in the range of 0.8 to 1.2 m/s. Current velocities are relatively low in the trough region landward of the bar.

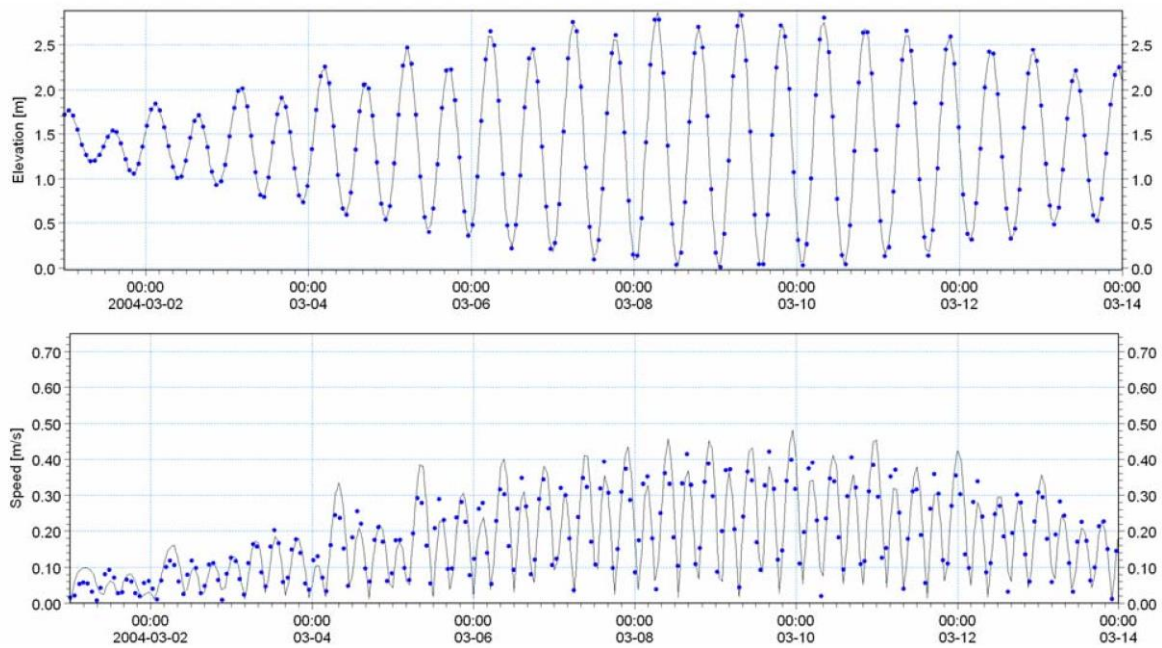

Figure 10. Computed tidal elevations and tidal currents, depth 10 m.; March 2004 (blue dots are model results from the Icelandic Maritime Administration) (DHI,2007).

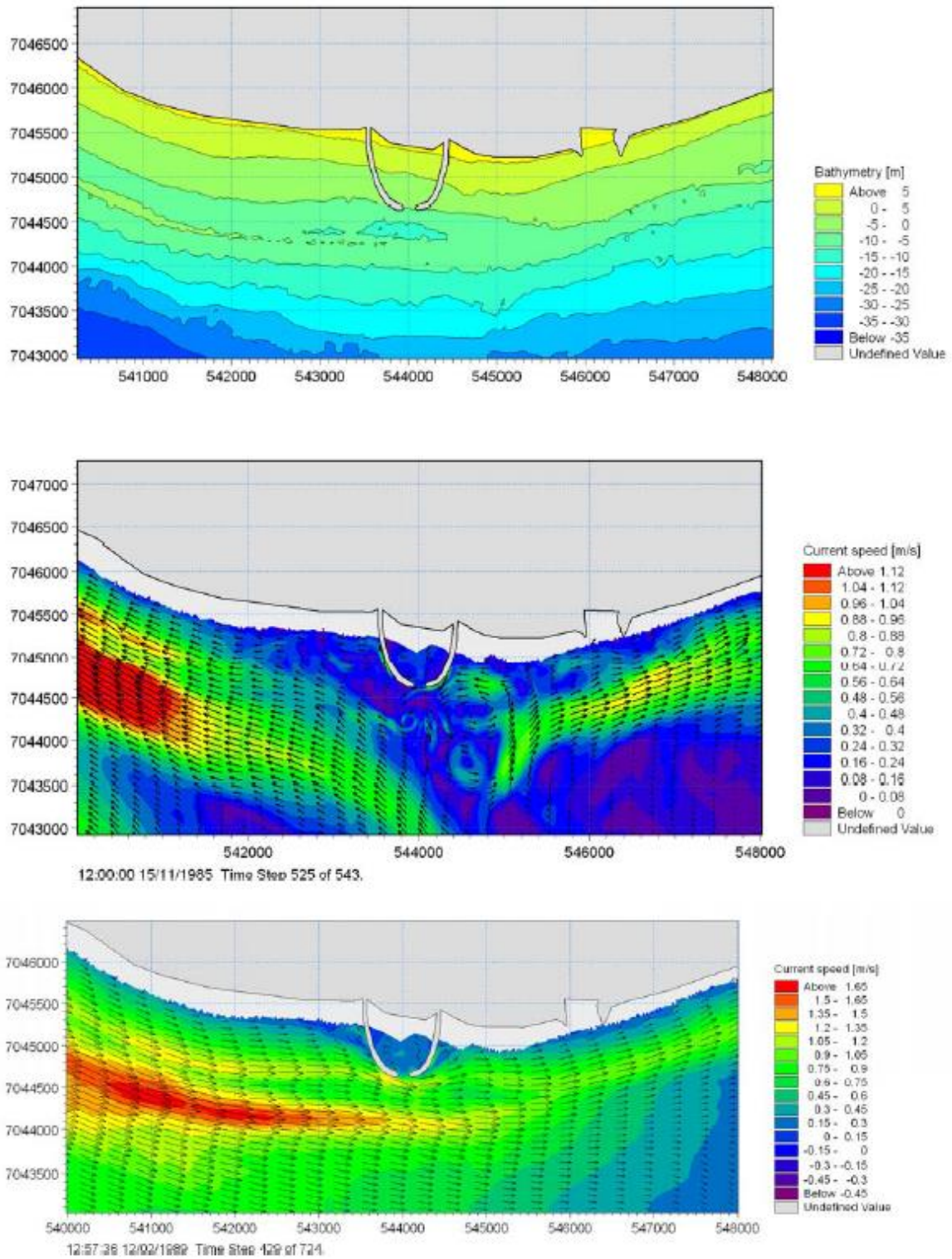

Figure 11. Computed current patterns for waves from the south (upper) and from the southwest (lower) (DHI,2007).

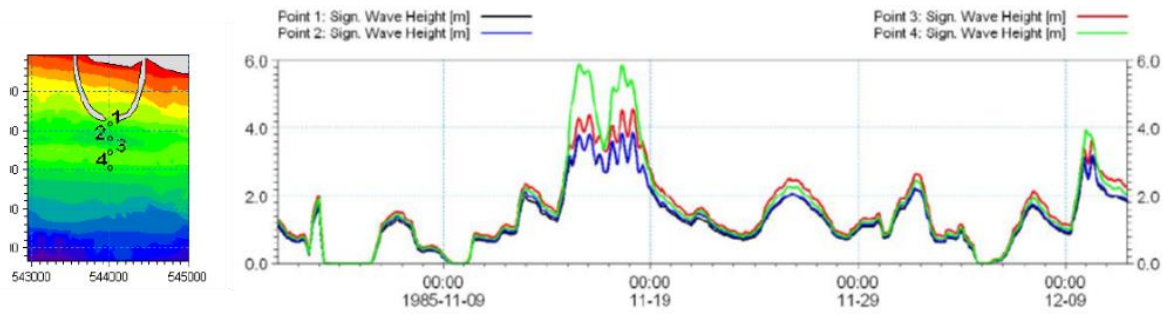

Figure 12. Computed wave height at 4 locations for a storm in November 1985 along a navigation line normal to harbour entrance (DHI,2007).

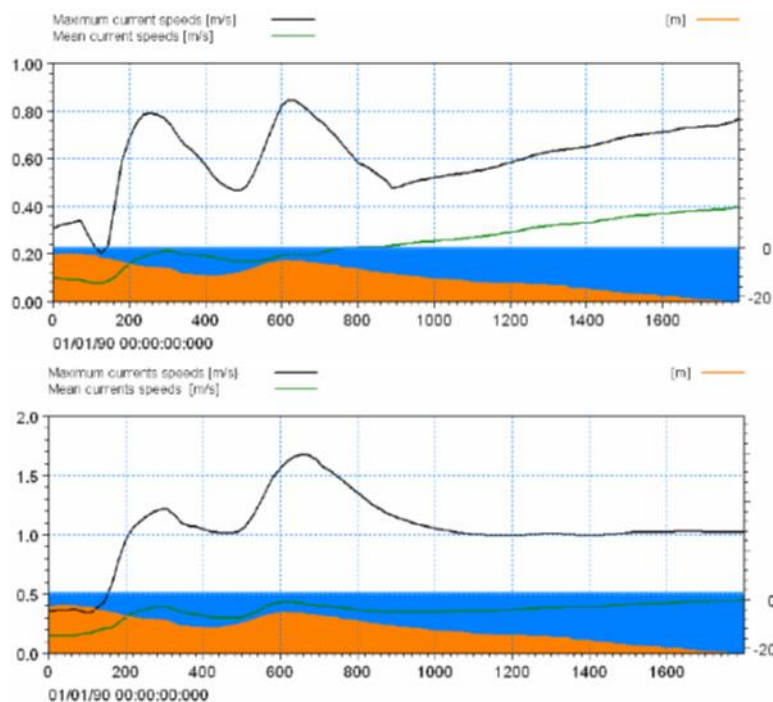

Figure 13. Computed mean and maximum current velocity along a navigation line normal to harbour entrance: November 1985 (upper) and February 1989 (lower) (DHI,2007).

2.2.2 Historical shorelines, longshore sand transport and overall sediment budget

DHI analysed the long-term shoreline developments based on 7 sets of aerial photos from 1954 to 2000. It appears that the historical shoreline is rather stable around the planned harbour location, whereas the shoreline variability is up to 300 m to the east of the location and 100 m to the west of the location.

DHI (DHI, 2006; DHI, 2007) used the 1D LITPACK-model to determine the net and gross annual longshore transport rates based on the available modelled wave data at the time (period 1979-2004). The model results indicated annual eastward littoral transport rates up to 0.5 million m³/year and westward values up to 1 million m³/year (Figure 14). The littoral drift varies not only along the coastline but also strongly within the year and from year to year. It was found that most of the time

the littoral drift is to the east at all points, but short severe south-easterly wave events lead to short periods of high transport rates to the west. Longshore transport was shown to be maximum in the winter months, December to March.

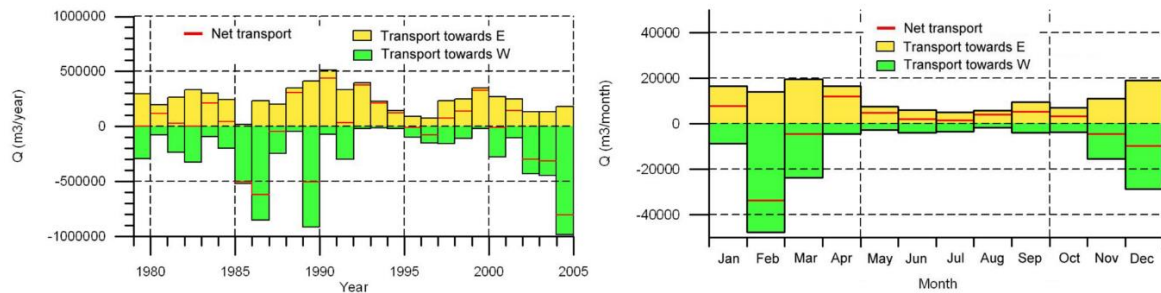

Figure 14. Longshore sand transport based on 1D LITPACK-model at harbour location; annual values (left) and monthly-averaged (right) (DHI,2006; 2007).

DHI furthermore used the 2DH-model to determine the longshore transport rates, resulting in an annual net transport value of 270,000 m^3/yr to the east and an annual gross transport of 950,000 $m^3/year$. Figure 15 shows the computed cross-shore distribution of the long-shore transport at the proposed harbour location. The long-shore transport is concentrated on the bar and the inner part of the profiles. The net long-shore transport is westward on the bar and eastward at the inner part of the profile. The longshore transport at locations west of the planned harbour is eastward and much higher (up to 0.5 million $m^3/year$ to east) due to a dominant wave direction from the southwest. The coastal corner in the lee of the Westman Islands is an accretional area.

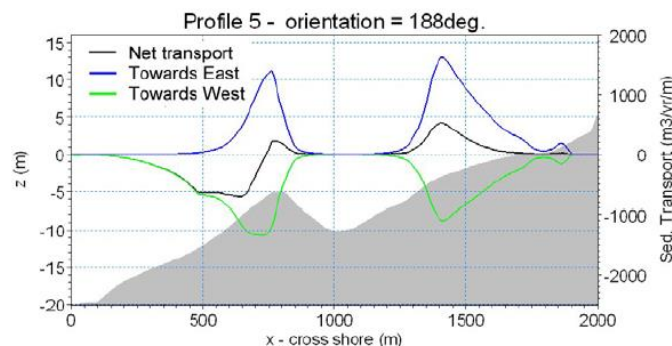

Figure 15. Computed cross-shore distribution of longshore transport at the proposed harbour location (DHI,2006;2007).

2.2.3 Morphological behaviour of the outer bar

DHI has given much attention to the calibration and validation of their models with respect to the short-term morphological behaviour of the outer bar (growth, decay and lateral infill at depression due to longshore transport). At the location of the planned harbour, the outer bar has a marked, dynamic depression at a level around -7 m and migrates east towards the spit location from time to time. The model was able to represent some basic features of the bar and spit behaviour (migration of bar over 500 m to the east and erosion of spit during winter period 2004 to 2005). The model performance was best with a sand diameter of 0.2 mm which is slightly smaller than the area-mean sand size of 0.25 mm. However, the sand diameter at the outer bar crest is 0.35 mm.

The main attention was focused on understanding the dynamics of the outer bar and the bar depression (persistent feature prior to 2006) during two extreme events. The first event was the November 1985 storm during which sand transport was to the west and the bar depression was maintained. The second event was the February 1989 storm where transport was to the east and the bar depression was filled up with sand. Given the fairly constant cross-shore position of the outer bar, it was assumed that bar migration processes can be represented by a depth-averaged model neglecting wave-related cross-shore transport processes. Some sensitivity runs were done with a fully 3D-model. The period-averaged cross-shore transport along the bar was found to decline towards the gap.

Analysis of model results showed a tendency of the outer bar near the harbour location to break up in conditions with eastward flow and transport conditions. The seaward deflection of sediment on the outer bar is caused by cross-shore transport processes (rip current) which are pronounced at the location of the bar depression.

Figure 16 shows calculated sediment transport patterns for conditions with strong eastward transport around the harbour breakwaters. The deflection of sediment is primarily caused by the generation of a rip current due to alongshore variations in the wave set-up (alongshore variations in wave breaking caused by the shadow effect of Westman Islands). This effect is strongest with waves from the southwest under an angle of 45°. The results show that the rip current will maintain the bar depression.

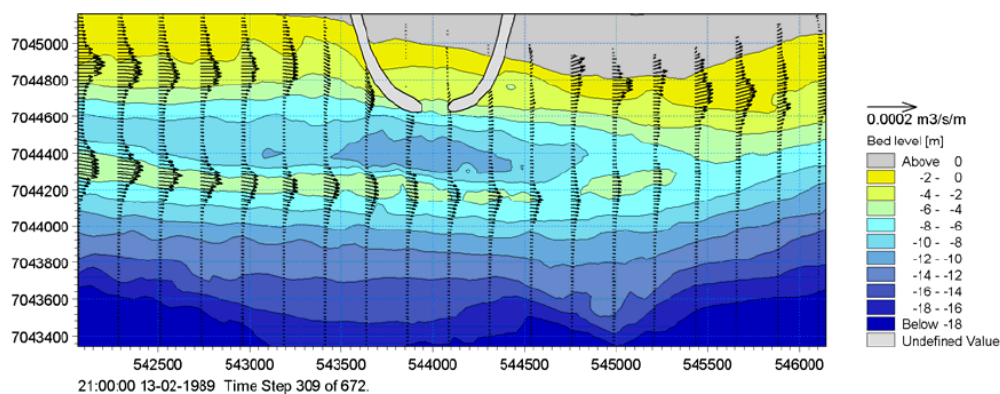

Figure 16. Sediment transport during February 1989 storm (DHI,2007).

Model runs were performed with the following artificial modifications of the outer bar in front of the breakwaters:

- shallower depression (bar fill of 2 m over 300 m alongshore); the water depth along the original bar is restored rather quickly to the original depth at approximately 5 m; the sand volume is moved landward into the trough region;
- deeper depression (increase of water depth to 7 m over 150 m alongshore); the deeper area migrates eastwards and is found to be maintained with a slight tendency for further deepening; sand is transported eastward and seaward.

Model runs were furthermore performed with and without the proposed harbour. It was found that the harbour blocks sediment transport at the inner bar and instead directs it around the harbour. Additionally, sediment transport and associated morphological evolution of the bar is only marginally

influenced by the harbour, with a slight tendency for seaward displacement of the bar and lowering of the crest. It is stated by DHI that after the establishment of the new harbour, the water depths in the outer part of the beach profile will vary the same way as before construction and are not expected to be affected by the new harbour. Local erosion depth on the flanks of the two breakwaters may be as large as 3 m (DHI, 2008).

Maximum bed level changes along the shipping lane normal to the harbour entrance based on model results were estimated on the order of 0.2 m for the November 1985 storm and about 0.4 m at the bar crest for the February 1989 storm. Sand transport is maximum at the bar crest with breaking waves.

Since the original modelling, DHI has recalibrated and revalidated the morphodynamic model (DHI, 2013). The morphological model results showed good ability of the model to reproduce the sedimentation corresponding to the actual dredging rates in both the calibration and validation periods.

2.2.4 Morphological behaviour at the harbour entrance

Safe navigation conditions, according to pre-construction documentation, require a minimum (critical) water depth at the harbour entrance of about 5.5 m to CD (DHI, 2007) for a ferry with a draught of 3-3.5 m (Viggosson, Jónsdóttir, Sigurðarson, & Bernódusson, 2005). Model results from DHI (2007) show that the water depth in front of the harbour changes from 9 m to 6.5 m CD during storm events (short term). To estimate long-term changes in water depth in front of the harbour, the morphological model was run with stationary wave forcing. Four different conditions were studied. The starting bathymetry was set to May 2006 values. Moderate to rough south-westerly storms were found to give the smallest water depths of less than 5 m in front of the harbour entrance (see Figure 17). The most prominent development in the morphology was found on the updrift side of the harbour along the breakwater. Here a bar is building up to accommodate the bypass of sediment. The bar is seen to migrate towards the entrance. The build-up of the bar comes to an end as the equilibrium between the sediment transport capacity and the water depth is attained.

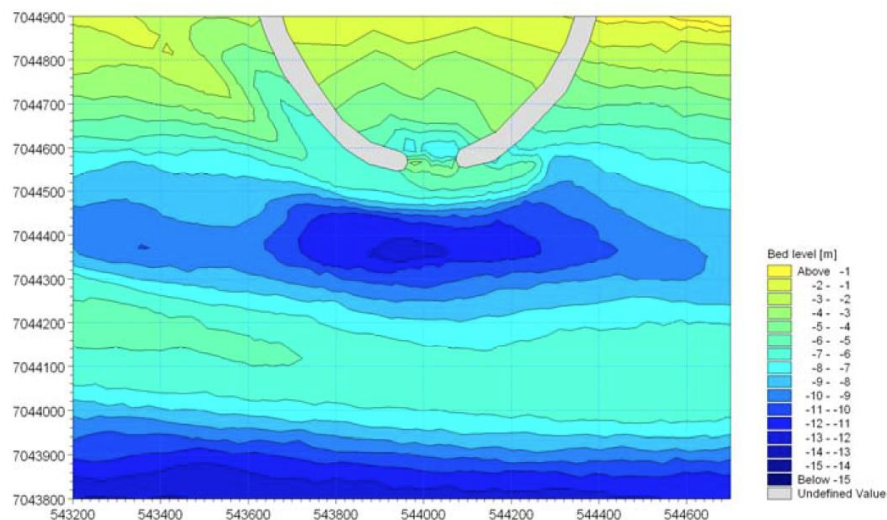

Figure 17. Final model bathymetry for rough south-westerly wave conditions following a starting bathymetry in May 2006 (DHI, 2007).

DHI performed model runs with a deepened initial bathymetry of -7 m (initial capital dredging) along the breakwaters and at the harbour entrance. No major bed level changes were observed in the model results. The computed water depths were even slightly greater, most likely due to the presence/generation of rip currents in the deepened area.

The breakwater tip configuration (Figure 18) was also studied. Most runs were done with an angle of 40°. Runs with an angle of 65° showed somewhat larger water depths in the harbour entrance due to a small increase in the current velocities during south-westerly conditions (DHI, 2007). The angle in the existing breakwater layout is near 75° (DHI, 2013).

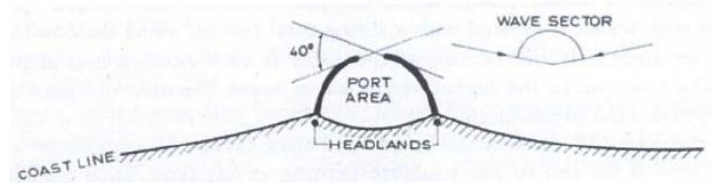

Figure 18. Configuration of breakwater tips (DHI,2007).

2.2.5 Shoreline morphology

Shoreline morphology in the vicinity of the harbour was studied by DHI (2007) using the 1D LITPACK-model. The model was set-up to calculate the coastline evolution starting from January 1989, taking the sediment load from the Markarfljót river into account with annual average sediment discharge of 150,000 m³/yr.

Figure 19 shows the estimated shoreline after 2, 5 and 10 years. The simulations were carried out with the harbour located at the proposed location and with a fixed river mouth. The coastline at the river mouth is only modified slightly during the 10-year simulation period whereas the coastline in the vicinity of the breakwaters changes significantly such that the coastline reaches the toe of the breakwaters after 10 years.

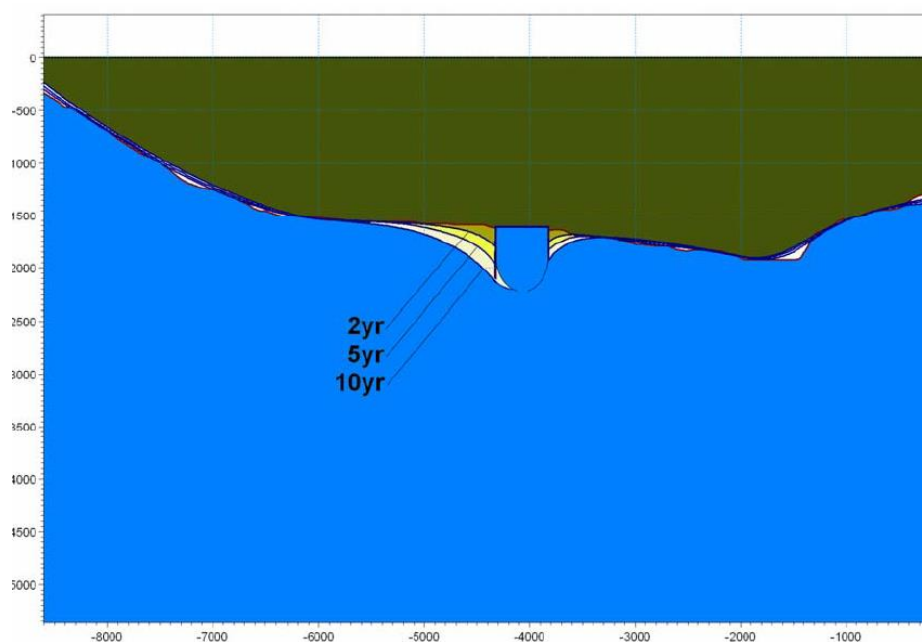

Figure 19. Computed shoreline development on west and east side of harbour (DHI,2007).

These 2D effects around the harbour are taken into account in the LITPACK-model with parametrization. However, by modelling the 2D effects with MIKE 21 FM the accumulation of sand near the breakwater is calculated much lower, although significant changes are estimated as shown in Figure 20.

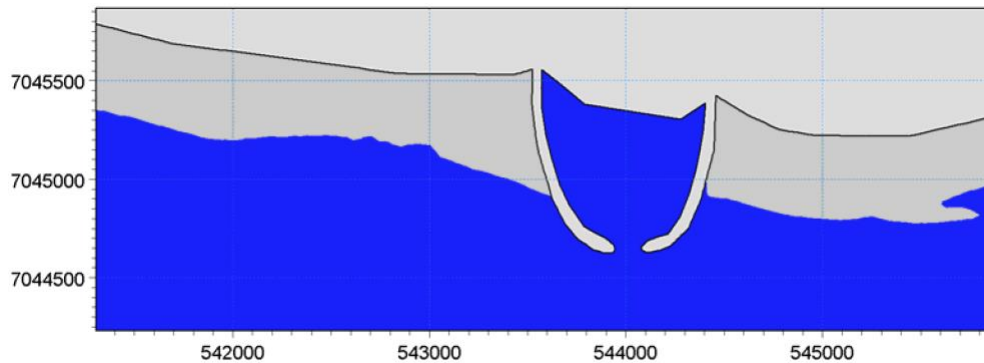

Figure 20. Equilibrium coastline after 10 years in MIKE21FM (DHI,2007).

2.2.6 Sedimentation inside the harbour

Sand

Sedimentation inside the harbour basin was not studied in great detail by DHI (2006; 2007), rather it was determined by applying an empirical rule. Sediment is transported into the harbour basin through the effect of circulation cells in the harbour entrance. These cells create a constant exchange of water (and sediment) between the sea and the harbour basin.

As a rough estimate, the following empirical rule of thumb for exchange of suspended sediment into a harbour basin was applied: $Q_s = 0.07 D \times V \times C \times W$

where Q_s is the annual sedimentation ($m^3/year$), D = water depth, V = current speed, C = mean concentration and W = width of the harbour entrance.

To estimate annual sedimentation rates and to account for the impact of waves, the formula has been interpreted in the following way: $Q_s = 0.07 W \times Q_L$

where Q_L = longshore sediment transport ($m^3/m/year$) passing the entrance.

The longshore transport rates were derived from the 2DH-model results (Table 3). Estimates were made for the initial stage, just after construction of the breakwaters. Furthermore, equilibrium values were estimated, where the morphology and coastline have attained an equilibrium profile around the breakwaters.

The gross sediment transport passing the harbour in the equilibrium case where the depth was expected to be approximately 5-6 m was roughly assessed based on the assumption that the gross transport close to the mouth of the harbour in the equilibrium situation is of the same order of magnitude as the present (pre-construction) gross transport on the outer bar. This was assessed to be a conservative assumption. The sedimentation in the equilibrium case was thereby considered approximately $15,000 m^3/yr$ for an entrance width of 90 m. DHI ascribed a safety factor of 2 on the sedimentation due to the large uncertainty of the sediment transport calculations, resulting in a value of $30,000 m^3/yr$ as shown in Table 3. The infill of sediment into the harbour from 3D helical motion and sediment transport induced by second order wave phenomena (wave asymmetry, streaming, wave drift) was not accounted for in the above estimate as it was assumed to be of minor importance.

DHI concluded that deposition of sand would not be evenly distributed within the harbour. The coarser fractions of the trapped sediment were expected to settle in the area just inside or between the breakwaters while finer fractions of suspended material would settle along the inner side of the breakwaters and further inside the harbour.

Table 3. Predicted sedimentation rates inside harbour basin after construction for three entrance widths (DHI,2007).

| | MIKE 21 FM (W=70m) Weighted | MIKE 21 FM (W=90m) Weighted | MIKE 21 FM (W=110m) Weighted |
|--|-----------------------------------|-----------------------------------|------------------------------------|
| Initial rates after construction [m ³ /year] | 4,400 | 5,600 | 7,000 |
| Equilibrium rates after construction [m ³ /year] | 25,000 | 30,000 | 39,000 |

Fine suspended sediments

DHI made a distinction between accumulation of sand and fine sediments (< 63 µm). Fine suspended sediments (silt and mud) are released by the river during periods of high discharge. Aerial photographs of the sediment plumes at the river mouth suggest that a large part of the fine sediment is transported a significant distance into the open sea. During events with waves from easterly directions, sediment-laden water was expected to pass the harbour entrance. Some amount of the sediment was expected to enter the harbour basin due to the daily exchange of water generated by the tides. The volume of water that enters the harbour each day (tidal prism) was estimated approximately 600m x 800m x 2m = 960,000 m³. This means that each month a volume of approximately 960,000 m³ x 30 x 2 = 58 million m³ of water enters the harbour basin. Assuming a significant concentration of 100 mg/l for 2 months per year, the deposition of fine sediments inside the harbour was estimated as 4,400 m³ per year. The fine sediments were expected to accumulate evenly across the entire harbour basin resulting in an annual sedimentation of about 1 cm (DHI,2007). DHI concluded that more accurate estimates were subject to measurements of fine suspended sediments at the location of the harbour.

2.3 Post-construction hydro-morphodynamic studies

The Landeyjahöfn harbour was constructed in 2009 according to design specifications. Soon after operation of the harbour began in 2010, severe sedimentation problems were observed. Post-construction studies have focused primarily on sedimentation processes and maintenance dredging operations. In response to the sedimentation issues, DHI was asked to perform additional modelling of the morphodynamic processes in order to better understand the root of the problems and determine potential solutions (DHI, 2013).

2.3.1 Annual waves, extreme storm waves and currents

DHI improved the wave model predictions (DHI, 2013) by refining grid resolution in the lee of the Westman Islands and improving wave data at the seaward boundary. Comparison of model results shows a significant increase of south-easterly waves at Landeyjahöfn harbour after revision of the model.

DHI analysed a high-energy event occurring on March 6, 2011 with winds from the southwest at 247° (DHI, 2013). The computed wave patterns show much higher waves on the west of the harbour due to waves passing the Westman Islands on the west side. Wave height on the east side of the planned harbour in the lee of the Westman Islands are much smaller (Figure 21). According to the DHI analysis, significant wave height characteristics are:

- Significant wave height offshore Westman Islands = 8.3 m from direction 233°;
- Significant wave height at buoy BFD1 (Figure 21) = 4.8 m from direction 241°;
- Significant wave height at buoy BFD2 (Figure 21) = 3.5 m from direction 233°.

Wave data from buoy BFD2 for the year 2011 shows:

- Winter (Nov. - Feb.): 7 major storm events (1 per 2 weeks) with H_s in range 5 to 8 m;
- Spring/Autumn (March, April, Oct.): 15 storm events (1 per week) with H_s in range of 3 to 5 m;
- Summer (May-September): 15 minor events (1 per 1.5 weeks) with H_s in range of 2 to 3 m.

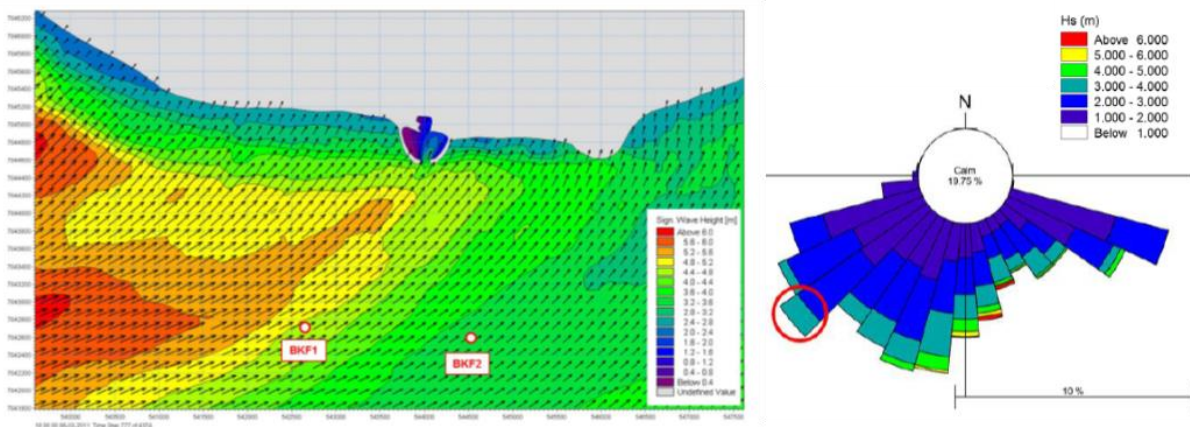

Figure 21. Computed wave patterns (left) on March 6, 2011. The wave rose (right) is based on model data from the right buoy location. The red circle shows the wave direction and wave height used for the computed wave patterns. A composite of figures in (DHI, 2013).

The IRCA compared wave data from buoys (including directional buoy), model results and radar data for the period June 2013 to July 2014 (IRCA, 2015a). Comparison of computed and measured wave heights shows good agreement for waves between 1 and 5 m. The DHI wave model slightly overpredicts (by 10% to 15%) heights for waves up to 3 m and slightly underpredicts (by 10% to 15%) heights for waves between 3 and 5 m. The peak wave period of the larger waves is substantially underpredicted (by 20%). Correlation between computed and measured wave directions at each time is poor, showing widely scattered results. The poor correlation might be explained by delay in the model; however, further comparison is needed to determine if that is the case.

Correlation between the radar data and the west buoy showed less correlation compared to the model results. The radar data indicates a more southerly wave direction when south-eastern waves are measured at the west buoy.

2.3.2 Historical shorelines, longshore sand transport and overall sediment budget

DHI performed a revision of the overall sediment budget because major changes to the nearshore wave direction were obtained in the revised wave field (DHI, 2013). The littoral drift was calculated on 10 coastal profiles (5 west of Landeyjahöfn harbour and 5 east of the harbour), see Figure 22. The alongshore spacing between the profiles is approximately 2 km and the orientation of each profile is carefully selected from the local orientation of the -10 m CD and the -5 m CD depth contours from the surveys taken 2006 and June 2012. Grain size variations along the profiles were included based on measured data. The near-shore wave climate was extracted from the revised wave hindcast model (Figure 23). It shows that the wave climate is strongly affected by the Westman Islands which are located 10 km south-southwest of Landeyjahöfn harbour.

The profiles WD and WC are exposed to the highest waves. However, these waves approach the coast with a small angle and cause therefore a limited amount of littoral drift. The profiles WA and OA are exposed to waves which are smaller but have a larger angle to the shore normal. Changes in wave height are therefore balanced by changes to the angle between the approaching waves and the shoreline orientation in the area west of Landeyjahöfn harbour.

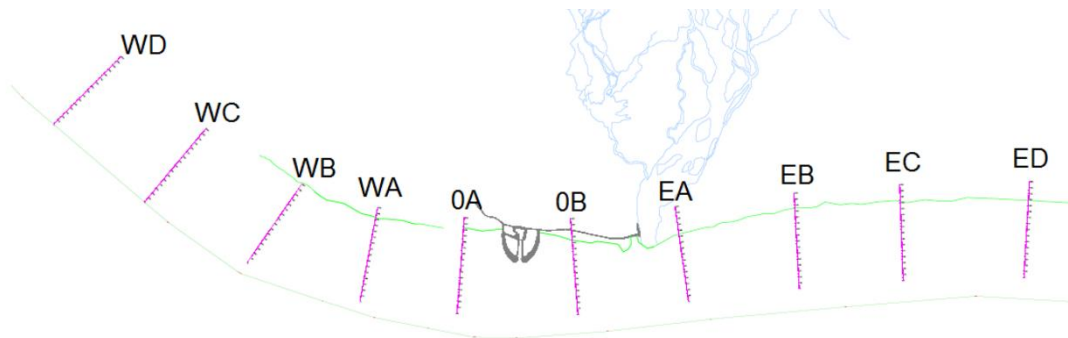

Figure 22. Location of coastal profiles (DHI,2013).

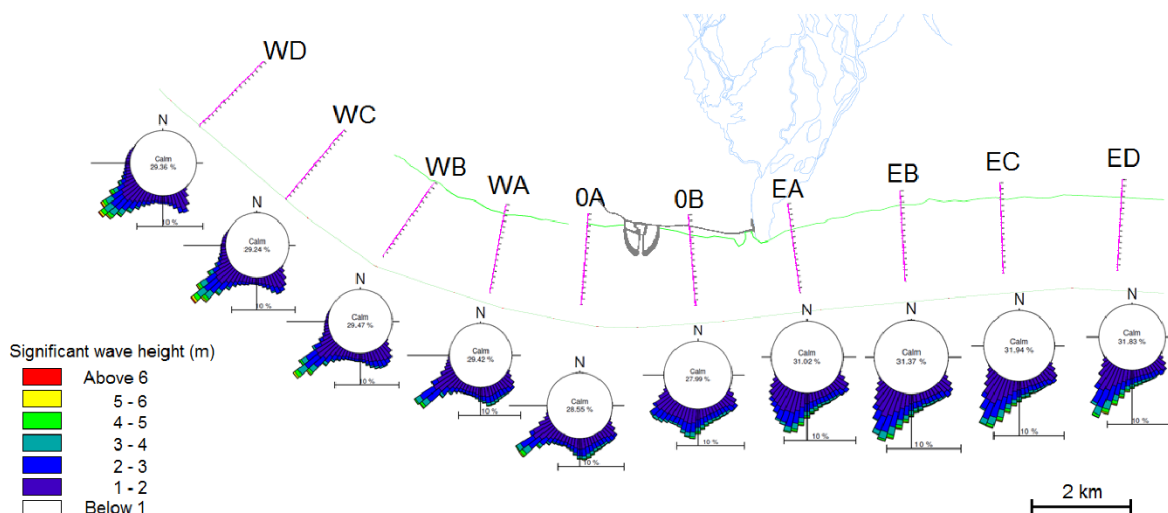

Figure 23. Computed wave roses based on revised model (1958-2012 modelled wave data) at depth of 15 m (DHI,2013).

Figure 24 shows the alongshore variation of the littoral drift averaged over 54 years based on computed values for 10 profiles. The sensitivity of the net transport to changes in the orientation of the shore normal is also indicated by showing the net transport if the profile orientation changes by ± 5 degrees. The orientation of the shoreline normal is assumed to be constant throughout the 54 year period.

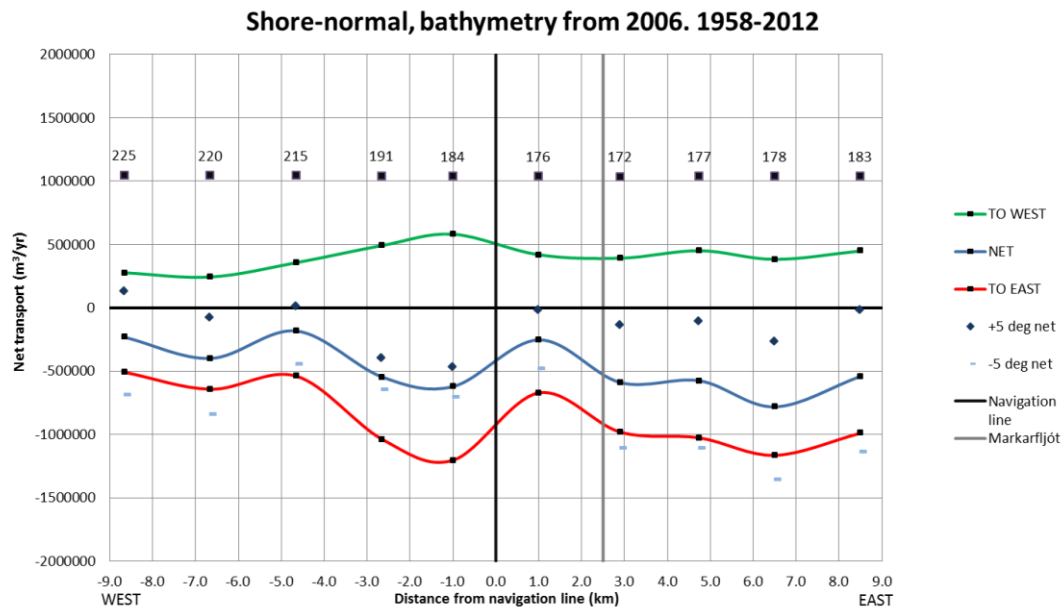

Figure 24. Longshore sand transport for an average year; locations of harbour and river are indicated (DHI,2013).

The calculated alongshore variations are expected to be due to uncertainties in the model. The net transport west of Landeyjahöfn harbour is thus estimated in the DHI (2013) report to be roughly 400,000 m³/yr with a gross transport of 1,200,000 m³/yr. The net transport east of Markarfljót river is estimated in the DHI (2013) report as roughly 600,000 m³/year with a gross-transport of 1,500,000 m³/yr. Markarfljót river is expected to balance the sediment deficit in net transport between these two areas, leading to an average supply of sediment from the river of 200,000 m³/year.

The longshore transport was also computed using the cross-shore profiles from 2012. No significant changes were found. The variations from year to year are large due to variations in annual wave climate. The standard deviation of the eastward transport is nearly twice the size of the standard deviation of the westward transport. Seasonal variations are also large. The largest net transport occurs consequently during the winter months December-March where the net transport clearly is towards the east. The seasonal distribution of the gross transport suggests that 68% of the total transport occurs during the four winter months, December-March.

2.3.3 Morphological behaviour at the harbour entrance

DHI studied the bar-trough system after construction of the harbour based on bathymetry data from the period 2010 to 2012 (DHI, 2013) as shown in Figure 25. The data from 2002 to 2006 were revisited and it was found that bar crest level was underestimated by about 1 m due to limited horizontal resolution of the sounding data. The results shown in Figure 25 have not been corrected to show the revised crest level. The temporal variability of the crest level in the years 2002-2006 showed that the crest level varied 1 to 2 m in response to changes in wave climate.

The bathymetric surveys around Landeyjahöfn harbour from the last decade (multibeam data) indicate that changes to the coastal profile have occurred. During the years 2002-2006 the coastal profiles west of Landeyjahöfn harbour were characterized by the presence of a large bar with a crest level of roughly -4.5 m CD. The crest level was 1 m higher in profiles 2-3 km west of the harbour while it was 1 m lower in profiles near the harbour. Landward migration of the bar was observed, most likely due to a milder wave climate from the west in 2009 and 2010.

The bar recovered during 2011 and 2012 starting in profiles west of the harbour. The alongshore averaged crest level was -3.5 m CD in the majority of the surveys from 2012. The crest level continued to be 1 m higher in the profiles 2-3 km west of the harbour and approximately 1 m lower in the profiles near the harbour compared to the average crest level along the bar.

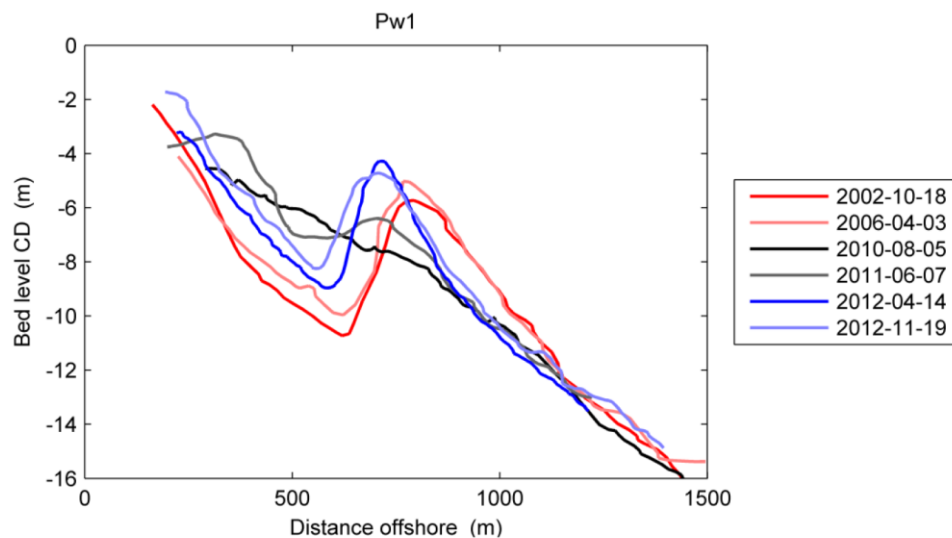

Figure 25. Cross-shore bed profiles at location 500 m west of harbour (DHI, 2013).

DHI used the revised morphodynamic model to study various changes to the harbour geometry (more streamlined breakwaters; under water berms) with the aim at reducing dredging volumes in and near the harbour entrance (DHI, 2013). All solutions were tested for a characteristic severe wave event combined with an average tidal variation. None of the local solutions were found to have potential to promote significant increase in bypass capacity and thereby significant increase in bypass depth.

DHI also studied various radical solutions:

- seaward extension of breakwaters with a spur-breakwater;
- underwater berm between harbour entrance and outer bar;
- shore-parallel breakwaters, also referred to as detached breakwaters (Figure 26);
- large sedimentation reservoirs with volume on the order of 0.5 million m³ on both sides (Figure 27);
- artificial retreat of coastline.

These solutions were tested in the numerical models for the same hydrographic conditions as the local solutions. Solution a, b, and e did not show significant improvements in the bypass capacity and thereby did not indicate significant improvement of the natural bypass depth. Solutions c and d were found to have positive effects.

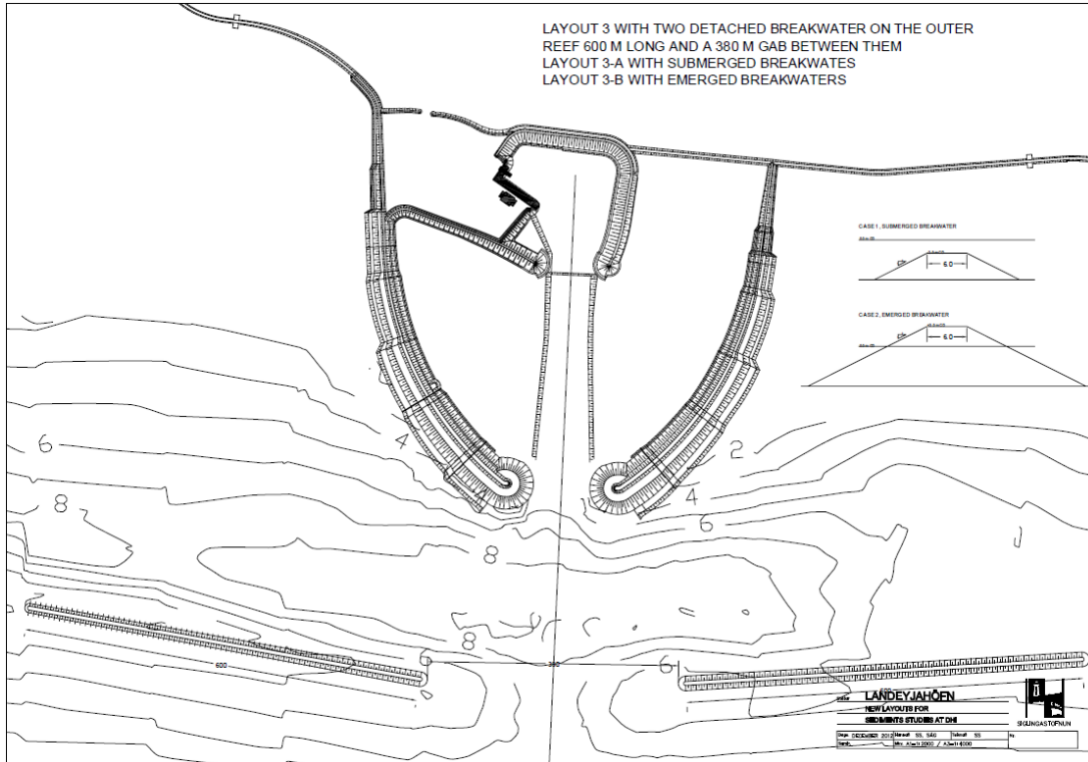

Figure 26. Proposal for detached breakwaters by DHI (2013).

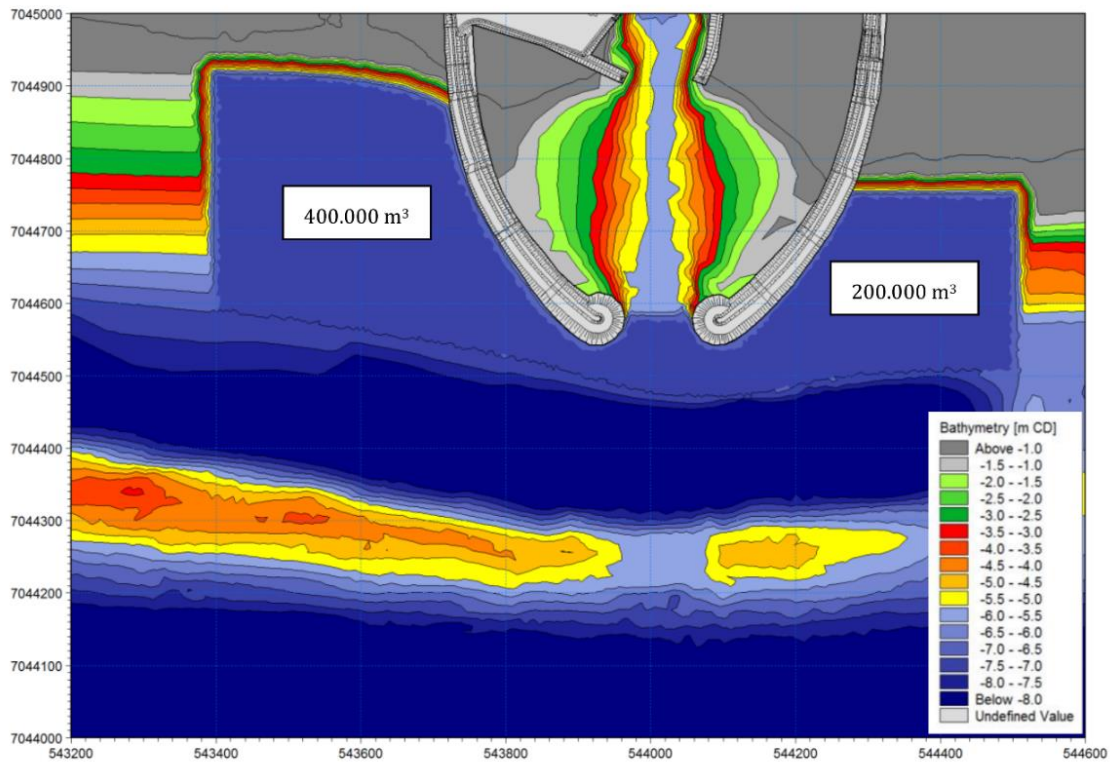

Figure 27. Large reservoirs on both sides of harbour (DHI,2013).



Professors Hanson and Larson from Lund University (Sweden) were asked to review (Lund University, 2013a; 2013b) the DHI study (2013). Their main comments focused on the lack of discussion of uncertainties and various inconsistencies of values in tables, figures and text. According to Hanson and Larson, numbers in the DHI report are sometimes presented without any justification or motivation. Their overall impression was that the DHI studies are quite comprehensive and of high quality, but that DHI relies too much on their models and that they are often not ready to discuss weaknesses or uncertainties in the model results. Several examples were given by Hanson and Larson. Often, the model shows good results in hindcasting measured data, but forecast results are less good. DHI is criticized for presenting results of wave propagation patterns, current patterns, and sediment transport patterns for each layout, but information on the morphologic evolution and the corresponding volumetric changes are missing.

Hanson and Larson (Lund University, 2013b) also provide a discussion on relative and absolute values of the longshore transport rates. According to DHI (2013), the relative performance of the model for longshore transport is of main importance for evaluating the different design alternatives, whereas the absolute values are of less importance. This is not true for the design of the reservoir sizes as this depends strongly on absolute values. Furthermore, the transport rates on both sides of the harbour are not interpreted correctly (Lund University, 2013b).

Hanson and Larson (Lund University, 2018) give a discussion on the sediment transport and deposition around the harbour entrance. They made estimates of longshore transport based on the LT-equation of Kamphuis resulting in an annual net value of 0.54 million m³ to the east and annual gross values of 1.66 million m³. The IRCA (2020) has estimated longshore transport with the same method for each week from week 27 in 2010 to week 5 in 2020, as well as average longshore transport over the entire period for 7 locations located directly at the entrance of the harbour and 1, 2 and 3 km to the east and west of the harbour. The results (Figure 28) show significant transport during the winter and minimal transport during the summer months, as expected. The sum of the eastward and westward longshore transport for the average transport suggest that the gross values are similar to the estimates of Hanson and Larson (Lund University, 2018) with net transport to the east. The ratio of the annual dredged volumes and gross long transport is found to be about 0.15 for 2011 to 2014 and increasing to 0.45 for 2014 to 2017.

The IRCA (2015c) gives an overview of survey areas for analysis of bathymetry data (Figure 29), however, deposition rates are not given. In addition, the IRCA (2018b) studied the deposition and erosion over a short winter period between December 27, 2017 and January 5, 2018 (Figure 30).

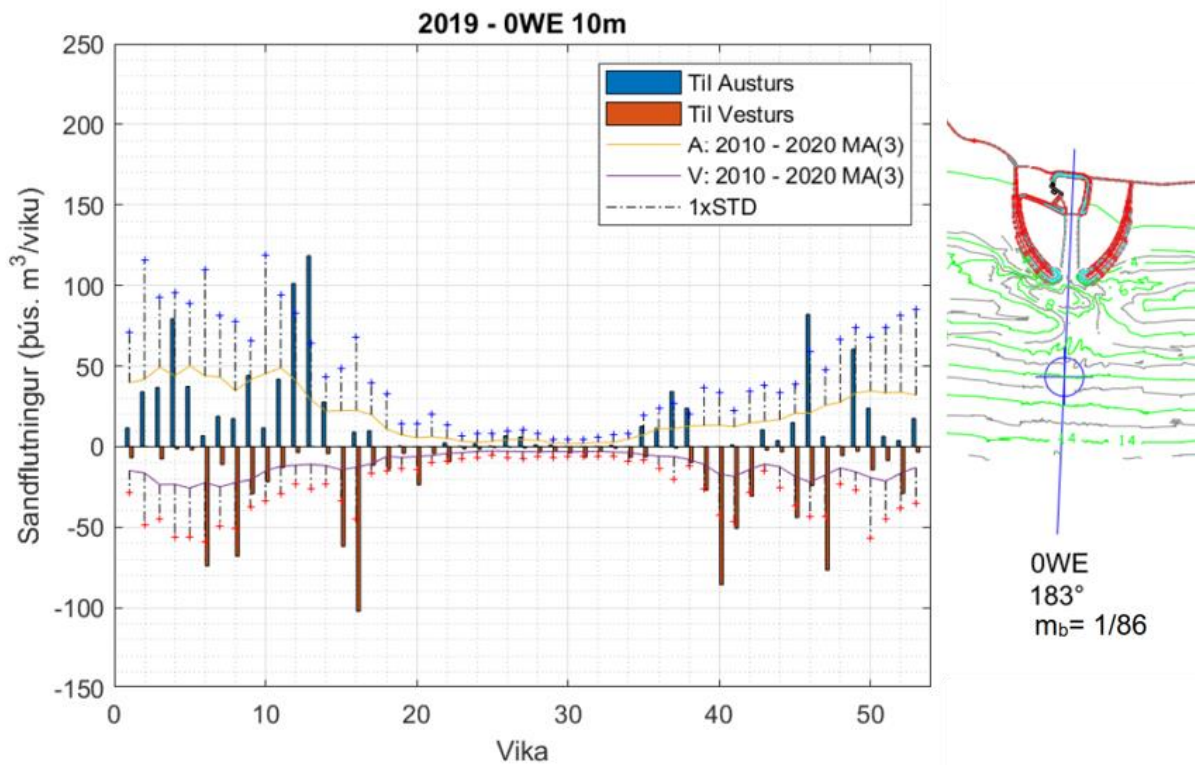

Figure 28. Weekly estimated longshore transport for the year 2019 at 10 m depth in front of the harbour entrance (location shown to the right) compared to the average transport for the period week 27 in 2010 to week 5 in 2020. A composite of figures from IRCA (2020).

| | Area m ² | Longshore boundary | Crossshore boundary |
|----|---------------------|---------------------------------------|-------------------------------|
| A1 | 330.952 | From Centerline-400m E surveyline | from shore to 13m counterline |
| A2 | 530.562 | From 400m E to 1000m E surveyline | from shore to 13m counterline |
| A3 | 1.532.838 | From 1000m E to 3000m East surveyline | from shore to 13m counterline |
| W1 | 325.639 | From Centerline to 400m W surveyline | from shore to 13m counterline |
| W2 | 578.280 | From 400m W to 1000m W surveyline | from shore to 13m counterline |
| W3 | 2.072.437 | From 100m W to 3000m W surveyline | from shore to 13m counterline |

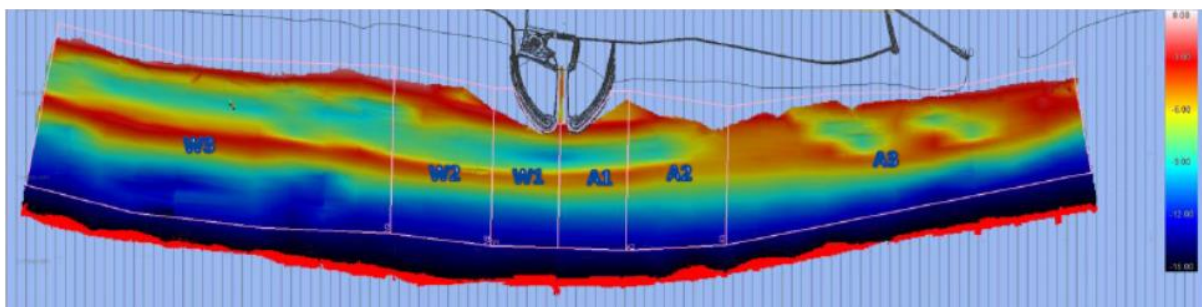

Figure 29. Definition of survey areas (IRCA, 2015c).

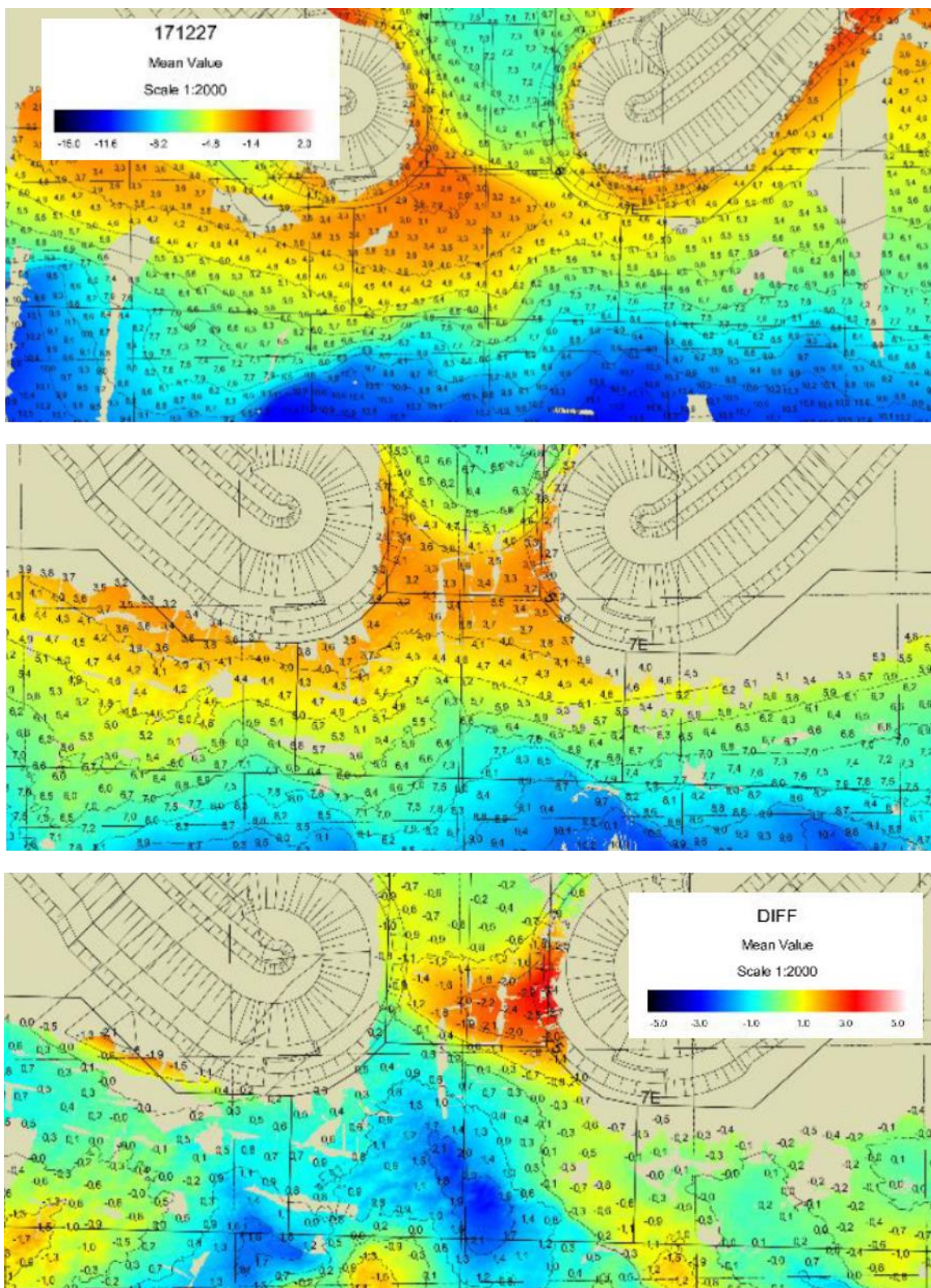

Figure 30. Bathymetry December 27, 2017 (top), January 5, 2018 (middle) and difference map (bottom) (IRCA, 2018b).

The IRCA (2018a) studied depth variations (to CD) at various locations near the harbour entrance over the period January 2016 to July 2018, see Table 4 and Figure 31. High bed level changes occur in the winter period.

Table 4. Depth changes near harbour entrance over period January 2016 - July 2018.

| Location | Mean depth (m) | Minimum depth (m) | Maximum depth (m) | Maximum temporal changes |
|--------------|----------------|-------------------|-------------------|---------------------------------------|
| 500 entrance | 6.6 | 3.1 | 10.2 | maximum 4 m in 1 month (Jan-Feb 2018) |
| 550 entrance | 6.5 | 2.9 | 9.8 | maximum 5 m in 1 month (Dec 2017) |
| 600 entrance | 7.8 | 4.6 | 10.2 | maximum 3 m in 1 month (Dec 2016) |
| 551 west | 5.6 | 3.7 | 7.4 | maximum 2 m in 1 month (Nov 2017) |
| 601 west | 7.5 | 4.5 | 10.5 | maximum 3 m in 1 month (Nov 2016) |
| 552 east | 5.7 | 3.5 | 7.5 | maximum 2 m in 1 month (Oct 2017) |
| 602 east | 7.4 | 5.9 | 9.8 | maximum 3 m in 1 month (Nov 2016) |

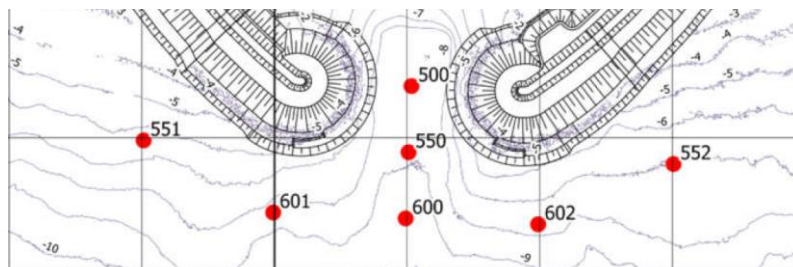

Figure 31. Overview of IRCA (2018a) monitoring points.

2.3.4 Sedimentation inside the harbour

Long-term deposition volumes inside the harbour basin are not presented in DHI’s post-construction study (DHI, 2013), and have not been performed to date.

2.3.5 Shoreline morphology

DHI (2013) gives a discussion of the shoreline around the harbour. In most cases, accretion occurs at the shoreline on the side of the harbour with the largest longshore sand transport and erosion occurs on the other side. At Landeyjahöfn harbour, the highest longshore transport is from west to east (eastward transport). Thus, shoreline accretion on the west side is expected. However, observations in 2012 show an opposite behaviour with more shoreline accretion on the east side, see Figure 32.

The main reason for this is considered to be the exceptional discharge of sediment on the order of 1 to 2 million m³ delivered by the Markarfljót river during and after the Eyjafjallajökull volcanic eruption in April 2010.



Figure 32. Shoreline around Landeyjahöfn harbour, Iceland. Photo taken by Guðmundur Alfurðsson on 25/09/2012 (DHI, 2013).

2.3.6 Dredging volumes

Monthly and annual dredging volumes from the IRCA are given in Table 5 for years 2011-2018, excluding the second half of the year 2018. The total 2018 dredging volumes were 471,185 m³ (IRCA, 2019) and 2019 volumes were 317,700 m³ (Morgunblaðið, 2020). Judging from reported total dredging volumes during 2010-2018 (3.8 million m³) (VSÓ ráðgjöf, 2020), dredged volumes in 2010 were as much as 0.5 – 0.7 million m³. The exceptionally high initial dredging in 2010 was considered to be caused by the high river loads from Markarfljót following a sub-glacial eruption in April of 2010. The total dredged volume for the years 2010 to 2019, both years included, was about 4.1 million m³ (Morgunblaðið, 2020). Expected dredging volumes for 2020 are about 300,000 to 500,000 m³ (Morgunblaðið, 2020).

After 2010, annual dredging volumes are in the range of 0.2 to 0.6 million m³ per year. The largest dredging volume over one month was about 0.2 million m³ in April 2016 and October 2015. A noticeable increase in dredging is observed in 2015 and onwards.

Table 5. Dredging volumes from IRCA dredging summary documents.

| | Jan | Feb | Mar | Apr | Mai | Jún | Júl | Ág | Sep | Okt | Nóv | Des | Samtals |
|---------|--------|---------|---------|---------|---------|--------|--------|---------|---------|---------|---------|--------|-----------|
| 2011 | 0 | 0 | 17.828 | 24.427 | 54.475 | 5.651 | 9.153 | 39.349 | 0 | 57.254 | 22.751 | 54.132 | 285.020 |
| 2012 | 3.347 | 0 | 13.949 | 111.615 | 2.758 | 0 | 15.387 | 10.647 | 32.884 | 23.810 | 15.762 | 3.053 | 233.211 |
| 2013 | 0 | 0 | 104.504 | 69.158 | 1.758 | 0 | 0 | 3.678 | 15.484 | 19.432 | 35.710 | 0 | 249.722 |
| 2014 | 12.902 | 47.718 | 16.904 | 52.833 | 1.976 | 0 | 0 | 13.107 | 0 | 40.358 | 11.504 | 10.857 | 208.159 |
| 2015 | 2.177 | 25.188 | 954 | 99.830 | 74.277 | 5.539 | 0 | 39.872 | 96.010 | 201.081 | 30.001 | 15.390 | 590.318 |
| 2016 | 13.656 | 17.705 | 40.792 | 198.896 | 107.025 | 0 | 0 | 0 | 4.194 | 50.450 | 66.102 | 349 | 499.168 |
| 2017 | 0 | 22.579 | 110.149 | 136.674 | 60.272 | 0 | 8.392 | 14.116 | 38.058 | 115.836 | 44.179 | 0 | 550.256 |
| 2018 | 0 | 0 | 145.910 | 137.133 | 23.073 | 65.831 | 0 | 0 | 0 | 0 | 0 | 0 | 371.947 |
| Samtals | 32.081 | 113.189 | 450.988 | 830.567 | 325.614 | 77.021 | 32.932 | 120.769 | 186.630 | 508.220 | 226.010 | 83.781 | 2.987.801 |

2.4 Information gaps

During compilation and review of the available existing data, several important information gaps were identified. These gaps include both data measurements themselves as well as analyses of existing measurement data and vary in their importance with regards to the present evaluation. The majority of information gaps identified relate to ocean forcing and sedimentation processes, assessment of historical maintenance dredging measures and analysis of data related to harbour utilization. A detailed list of these information gaps is provided in Chapter 5 along with related discussion and recommendations for filling the gaps.

3 Additional data collection and analysis

As mentioned previously in Chapter 1, the Ministry defined a framework for the present independent evaluation with a predetermined basis for budget and timeline, placing a clear focus on utilization of available existing data. Acquisition and analysis of data within information gaps identified during the review process do not fall within the defined framework, and therefore must wait until later stages in the overall evaluation process. However, the consortium identified specific information gaps that were necessary to address immediately in order to define the next stages in the path towards a comprehensive evaluation of Landeyjahöfn harbour. Therefore, these gaps were partially filled by the consortium during the present evaluation project. A description of the information collection and data analysis work performed by the consortium in order to address these information gaps is provided in Chapters 3.1 – 3.3.

3.1 Operational data regarding the ferry

Lack of documentation on the ferry itself and the perspective of local seafarers who have extensive experience related to the harbour (captains and officers on the Herjólfur ferry as well as port directors) was particularly noticeable as information was accumulated during the review process. To compensate for this lack of perspective, attempts were made to find such documents, however, without success. In an effort to remedy this lack of essential information, the consortium made an effort to acquire some of this information by conducting interviews and performing a site visit to Landeyjahöfn harbour, including sailing with the Herjólfur ferry round trip between Landeyjahöfn harbour and the Westman Islands. The site visit was planned in consultation with the Herjólfur ferry managing director, Guðbjartur Ellert Jónsson, and three ferry captains, Gísli Valur Gíslason, Ívar Torfason and Sigmar Logi Hinriksson. Valuable information was collected during the trip through interviews and direct observations during rather uncalm navigational conditions. Ironically, the planned ferry trip was cancelled due to bad weather conditions and high waves, despite the mid-summer timing of the trip. However, the trip was made later that same day after weather conditions improved.

In preparation for and during the site visit, two captains of the Herjólfur ferry (Brynjar Smári Unnarsson and Sigmar Logi Hinriksson), a chief engineer (Elías Jónsson), maritime pilot at the Westman Island harbour (Sveinn Rúnar Valgeirsson) and the former port director at Landeyjarhöfn harbour (Sigmar Jónsson) were interviewed. The interviewees all had similar perceptions on the poor utilization of the harbour. Recognizing the overall need for maintenance dredging, they still believe that harsh wave conditions outside the harbour is the dominant factor leading to ferry cancellations, more so than sedimentation issues, especially after the new ferry with less draught was put into service in the summer of 2019. It is worth noting though that since the new ferry became operational, depth conditions in the harbour and the navigational channel have been more favourable than during previous years according to the IRCA. Therefore, more time is needed to evaluate the real gain in harbour utilization resulting from the new ferry.

The former port director at Landeyjahöfn documented the sailing conditions (weather, wave and possible other factors) at the harbour in a diary and with photos for each day while working at the harbour. Furthermore, the ferry captains suggest that some records from the old ferry regarding navigational conditions and decisions on trip cancellations might have been saved. During the finalization of this report, the IRCA handed over some limited historic data on trips and cancellations

for the Herjólfur ferry, both from the Landeyjahöfn harbour and the alternative Þorlákshöfn harbour, which is utilized when Landeyjahöfn is closed.

A detailed analysis of harbour utilization has not been performed to date, which limits the present review and assessment process. All the above-mentioned information should be gathered and processed during subsequent evaluation work to form a suitable dataset on Landeyjahöfn harbour utilization. This will allow for a comprehensive analysis of the data taking into account all relevant factors affecting ferry operation. Such analysis will provide much needed estimates on the utilization rate of the harbour and allow for an integrated assessment of mitigation and improvement measures. An initial assessment of factors affecting ferry operation is provided in Chapter 4.1.

3.2 Analysis of longshore transport

As a check on the computational results presented in Chapters 2.2 and 2.3, some additional predictions were made by LVRS-Consultancy using fairly simple models within the context of this evaluation.

The main objective regarding the assessment of sedimentation processes associated with the Landeyjahöfn harbour is the quantification of the annual transport of sand passing the harbour entrance resulting in harbour deposition. Most of this sand is supplied by the longshore transport (LT) from western and eastern directions. The studies of DHI (2006, 2007 and 2013) present LT-values, as follows:

- DHI 2006: LT \cong 0.3 million m³/year to east; LT \cong 0.2 million m³/year to west;
- DHI 2007: LT \cong 0.6 million m³/year to east; LT \cong 0.35 million m³/year to west;
- DHI 2013: LT \cong 1 million m³/year to east; LT \cong 0.5 million m³/year to west.

3.2.1 Methods

Three different methods were used to get a better understanding of the variations involved. These methods are:

1. empirical equation;
2. longshore transport equation;
3. detailed numerical model CROSMOR.

Empirical equation

A very simple engineering rule for the longshore transport (in m³/s) is given by:

$$Q_{s,LT} = [(1-\varepsilon) \rho_s]^{-1} b_s h_s v_L c_s \quad (3.1)$$

with ε = porosity (unitless), ρ_s = sediment density (kg/m³), b_s = width of surf zone (m), h_s = mean water depth in surf zone (m), v_L = mean longshore velocity in surf zone (m/s), c_s = mean sand concentration in surf zone (range of 0.1 to 0.5 kg/m³).

Longshore transport equation

The longshore sand transport of Van Rijn (2014) is described by:

$$Q_{LS} = 0.00018 K (1-\varepsilon)^{-1} g^{0.5} (\tan\beta)^{0.4} (d_{50})^{-0.6} (H_{s,br})^{3.1} \sin(2\alpha_{br}) \quad (3.2)$$

with Q_{LS} = total longshore sediment transport (in m^3/s , incl. pores), ε = porosity ($\cong 0.4$), ρ_s = sediment density (kg/m^3), d_{50} = median grain size (m), $H_{s,br}$ = significant wave height at breaker line (m), θ_{br} = wave angle at breaker line, g = acceleration of gravity (m/s^2), $\tan\beta$ = slope of beach/surf zone, K = calibration factor (default=1).

The longshore sand transport rate in the surf zone is defined in terms of parameters estimated at the breaker line. Thus, the offshore wave climate has to be converted to a wave climate at the breaker line. Waves arriving from deep water are transformed in shallow water according to the laws of energy flux conservation and refraction (Law of Snell) for gradually varying bathymetry, yielding:

$$\sin\alpha_{br} = (L_{br}/L_o) \sin\alpha_o \quad (3.3)$$

$$H_{br} = K_{r,br} K_{s,br} H_o \quad (3.4)$$

with $K_{r,br}$ = refraction coefficient at breaker line and $K_{s,br}$ = shoaling coefficient at breaker line (van Rijn, 2011).

For gradually varying bathymetry these values are:

$$K_{r,br} = (\cos\alpha_o/\cos\alpha_{br})^{0.5} \text{ and } K_{s,br} = (n_o c_o/n_{br} c_{br})^{0.5} \quad (3.5)$$

with c = wave propagation velocity, n = coefficient, α = wave angle, index br = at breaker line and index o = at deep water.

The wave height at the breaker line, $H_{br} = \gamma h_{br}$, can be computed if the breaker depth (h_{br}) and the breaker coefficient ($\gamma = 0.6-0.8$) are known. Generally, this procedure requires iterative computations.

An estimate of the breaker depth can be obtained by applying (van Rijn, 2011):

$$h_{br} = ((H_o^2 c_o \cos\alpha_o)/(1.8\gamma^2 g^{0.5}))^{0.4} \quad (3.6)$$

Thus, wave refraction largely controls the orientation of the shoreline when relatively smooth and regular depth contours are present (neglecting cross-shore contributions).

CROSMOR-model

The CROSMOR-model is a numerical model for the computation of cross-shore and longshore waves, currents and transport rates and is based on cross-shore profile evolution as a function of time.

The propagation and transformation of individual waves (wave by wave approach) along the cross-shore profile is described by a probabilistic model (Van Rijn and Wijnberg, 1994, 1996) solving the wave energy equation for each individual wave. The individual waves shoal until an empirical criterion for breaking is satisfied. The maximum wave height is given by:

$$H_{max} = \gamma_{br} h \quad (3.7)$$

with γ_{br} as breaking coefficient and h as the local water depth. The default wave breaking coefficient is represented as a function of local wave steepness and bottom slope. The default breaking coefficient varies between 0.4 for a horizontal bottom and 0.8 for a very steep sloping bottom. The model can also be run with a constant breaking coefficient (input value). Wave height decay after breaking is modelled by using an energy dissipation method. Wave-induced set-up and set-down and breaking associated

with longshore currents are also modelled. Laboratory and field data have been used to calibrate and to verify the model. Generally, the measured $H_{1/3}$ wave heights are reasonably well represented by the model in all zones from deep water to the shallow surf zone. The fraction of breaking waves is reasonably well represented by the model in the upsloping zones of the bottom profile. Verification of the model results with respect to wave-induced longshore current velocities has shown reasonably good results for barred and non-barred profiles (Van Rijn et al., 2003; Van Rijn and Wijnberg, 1994, 1996).

The cross-shore wave velocity asymmetry under shoaling and breaking waves is described by the semi-empirical method of Isobe and Horikawa (1982) with modified coefficients (Grasmeijer & van Rijn, 1998; Grasmeijer, 2001). Near-bed streaming effects are modelled by semi-empirical expressions based on the work of Davies and Villaret (1997; 1998; 1999). The velocity due to low-frequency waves in the swash zone is also taken into account by an empirical method.

The depth-averaged return current (u_r) under the wave trough of each individual wave (summation over wave classes) is derived from linear mass transport and the water depth (h_t) under the trough. The mass transport is given by $0.125 g H^2/C$ with $C = (g h)^{0.5} =$ phase velocity in shallow water. The contribution of the rollers of broken waves to the mass transport and to the generation of longshore currents (Svendsen, 1984; Dally & Osiecki, 1994) is taken into account.

The sand transport of the CROSMOR2007-model is based on the TRANSPOR2004 sand transport formulations (Van Rijn, 2006, 2007a,b,c,d). The effect of the local cross-shore bed slope on the transport rate is taken into account (van Rijn, 1993, 2006).

The sand transport rate is determined for each wave (or wave class) based on the computed wave height, depth-averaged cross-shore and longshore velocities, orbital velocities, friction factors and sediment parameters. The net (averaged over the wave period) total sediment transport is obtained as the sum of the net bed load (q_b) and net suspended load (q_s) transport rates. The net bed-load transport rate is obtained by time-averaging (over the wave period) of the instantaneous transport rate using a formula-type approach.

The net suspended load transport is obtained as the sum ($q_s = q_{s,c} + q_{s,w}$) of the current-related and the wave-related suspended transport components (Van Rijn, 1993, 2006, 2007).

The current-related suspended load transport ($q_{s,c}$) is defined as the transport of sediment particles by the time-averaged (mean) current velocities (longshore currents, rip currents, undertow currents).

The wave-related suspended sediment transport ($q_{s,w}$) is defined as the transport of suspended sediment particles by the oscillating fluid components (cross-shore orbital motion). The oscillatory or wave-related suspended load transport ($q_{s,w}$) has been implemented in the model, using the approach given by Houwman and Ruessink (1996). The method is described by Van Rijn (2006, 2007a,b,c,d).

Computation of the wave-related and current-related suspended load transport components requires information of the time-averaged current velocity profile and sediment concentration profile. The convection-diffusion equation is applied to compute the time-averaged sediment concentration profile based on current-related and wave-related mixing. The bed-boundary condition is applied as a prescribed reference concentration based on the time-averaged bed-shear stress due to current and wave conditions. The sediment composition can also be taken into account (van Rijn, 1998).

3.2.2 Prediction results

Storm events

Four storm events with minor to extreme wave conditions were defined, and the offshore wave incidence angle was set to 30° (either from west or east). A summary of the offshore wave conditions is shown in Table 6.

Other input data: sand grain size $d_{50} = 0.35$ mm; slope surf zone 1 to 100; breaker coefficient = 0.6, tide and surge level at 2 m above mean sea level; storm duration = 24 hours.

The computed LT-values in m^3 per day (24 hours) are shown in Table 6.

The three methods predict values which are reasonably close together. The LT-values increase from about 15,000 m^3 per day for a minor storm event with waves of 3 m to about 500,000 m^3 per day for an extreme event with waves of 9 m. The LT-values of the detailed CROSMOR-model are considered most accurate.

Table 6. Longshore transport rates for storm events.

| Storm events | Offshore waves H_s (m) T_p (s) angle (°) | Water depth at breaker line (m) | Width of surf zone (m) | Mean long shore velocity (m/s) | Mean water depth in surf zone (m) | Mean sand concentration (kg/m^3) | Longshore sand transport (m^3/day) | | |
|--------------|---|---------------------------------|------------------------|--------------------------------|-----------------------------------|--------------------------------------|--|-------------|---------------|
| | | | | | | | Empirical equation | LT-equation | CROSMOR-model |
| Minor | 3; 10; 30 | 5 | 400 | 0.7 | 4 | 0.1-0.2 | 15,000 | 20,000 | 10,000 |
| Medium | 4.5; 12; 30 | 8 | 800 | 0.8 | 5 | 0.2-0.3 | 45,000 | 70,000 | 40,000 |
| Major | 6; 14; 30 | 10 | 1200 | 1.0 | 6 | 0.3-0.4 | 135,000 | 160,000 | 100,000 |
| Extreme | 9; 16; 30 | 15 | 1500 | 1.5 | 8 | 0.4-0.5 | 490,000 | 520,000 | 440,000 |

Figure 33 shows the cross-shore distribution of the significant wave height, longshore velocity and the longshore transport for each storm event based on CROSMOR-results. Waves higher than about 4.5 m mainly break on the outer bar. The maximum longshore velocity is in the range of 1 to 2 m/s. Two velocity peaks occur for waves higher than 4.5 m. Wave breaking on the outer bar results in a peak of the longshore velocity and transport landward of the bar crest.

Based on the results of Table 6, it is concluded that the LT-equation 3.2 yields LT-predictions which are somewhat too high (overprediction). This can be corrected by using a correction factor ($K=0.7$).

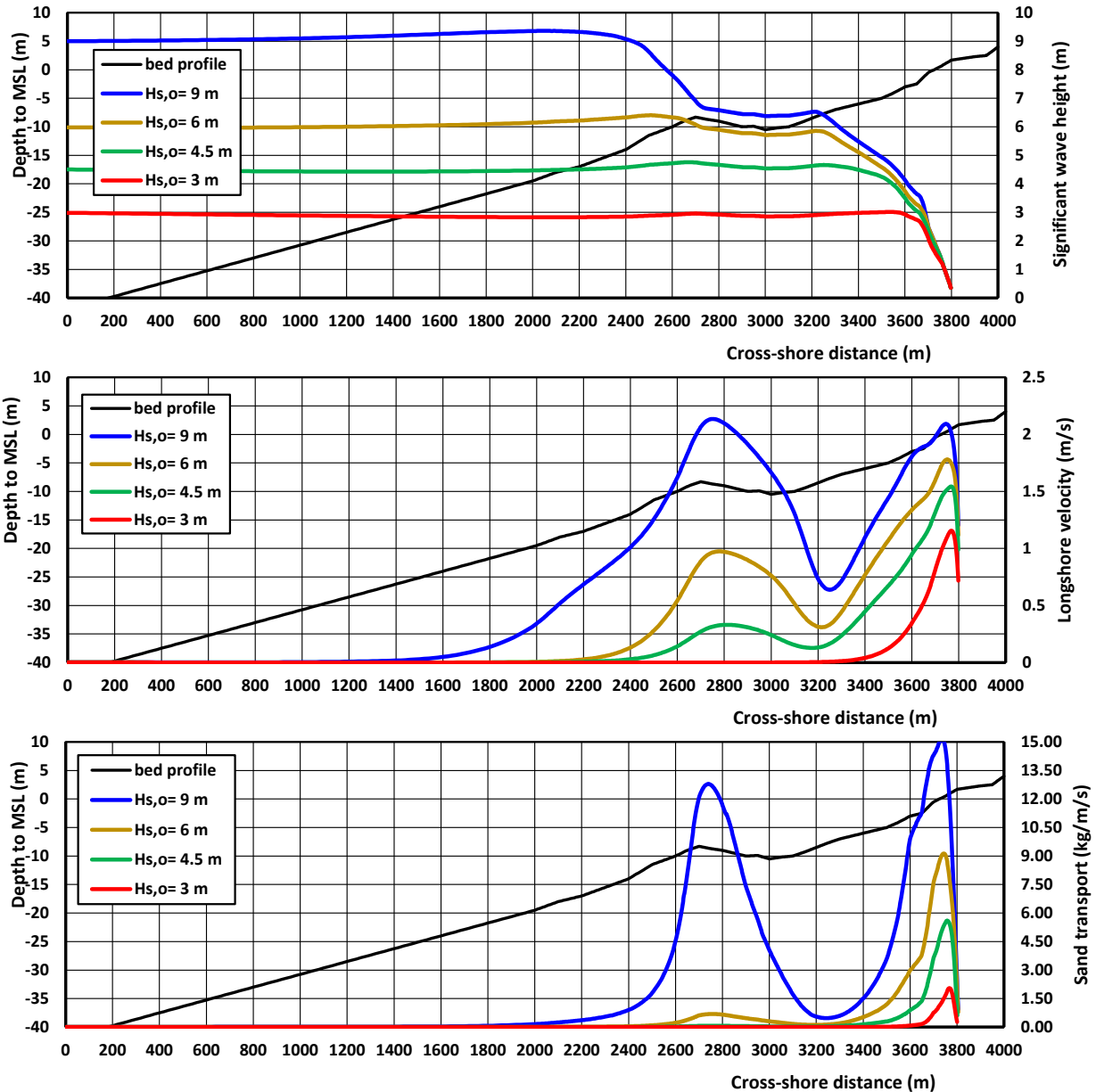

Figure 33. Cross-shore distribution of significant wave height, longshore velocity and longshore sand transport for 4 storm events based on CROSMOR-model.

Annual wave climate

Due to the lack of wave climate analysis based on available measurements, a preliminary analysis of the available wave data (August 27, 2015 to February 19, 2020) from the directional wave buoy BFK installed in 2015 (location shown in Figure 4) was made. The preliminary analysis was only performed to the extent to serve the limited scope of the evaluation framework.

The preliminary wave rose is shown in Figure 34 and tabulated data shown in Table 7. Figure 35 shows the wave exceedance curve; about 20% of the waves are smaller than 1 m (calm period), 5% of the waves are higher than 4 m and 2% of the waves are higher than 5 m.

The wave data of Table 7 have been used to compute the longshore transport rates using equation (3.2) and input data: $d_{50} = 0.35$ mm; surf zone slope 1 to 100, wave breaking coefficient = 0.6, peak wave periods based on Figure 36. The calibration coefficient is taken as $K = 0.7$, which gives a better

fit compared to the LT-values of the CROSMOR-model (see Table 6). The shore normal from the sea to the shore at the location of the harbour is about 0° to 2.5°.

The computed longshore sand transport rates (LT) are given in Table 8 for 2 nearshore wave climates. The red values of Table 8 refer to the most realistic situation. The LT-values are about 1 million m³ per year to the east and about 0.55 to 0.7 million m³ per year to the west. These values are in agreement with the LT-values given by DHI (2013). The annual-mean wave height (duration 365 days) which gives the same longshore transport to the east as the long term mean wave climate is H_s = 2.3 m, T_p = 10 s and angle = 30°.

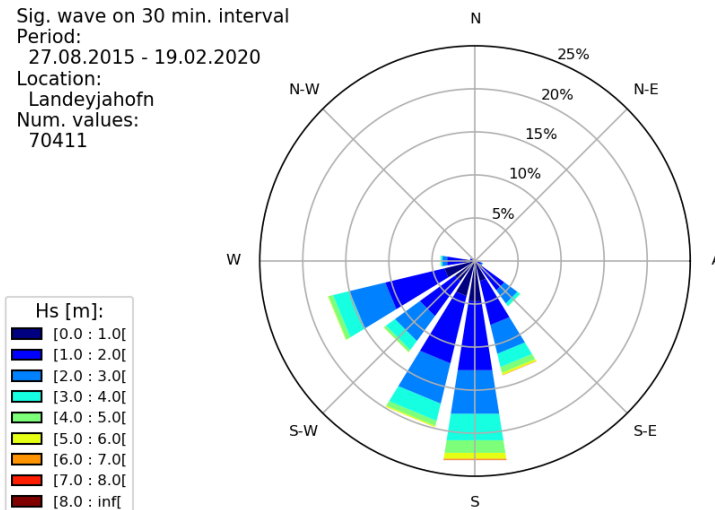

Figure 34. Wave rose for nearshore wave buoy BFK at depth of about 30 m (preliminary analysis).

Table 7. Wave rose data for nearshore wave buoy BFK at depth of about 30 m (preliminary analysis).

| Percentage (%) | | | Wave classes (m) | | | | | | | | Sum | |
|----------------|--------------------|--------|------------------|------|------|------|-----|-----|-----|-----|-----|-------|
| | Direction interval | | <1 (calm) | 1-2 | 2-3 | 3-4 | 4-5 | 5-6 | 6-7 | 7-8 | >8 | |
| N | 348.75 | 11.25 | 0.0 | 0.0 | | | | | | | | 0.1 |
| | 11.25 | 33.75 | 0.0 | 0.0 | | | | | | | | 0.0 |
| N-E | 33.75 | 56.25 | 0.0 | 0.0 | | | | | | | | 0.0 |
| | 56.25 | 78.75 | 0.0 | | | | | | | | | 0.0 |
| A | 78.75 | 101.25 | 0.0 | 0.0 | | | | | | | | 0.0 |
| | 101.25 | 123.75 | 0.2 | 0.6 | 0.2 | 0.0 | | | | | | 1.0 |
| S-E | 123.75 | 146.25 | 1.1 | 3.1 | 1.9 | 0.4 | 0.1 | 0.0 | 0.0 | | | 6.5 |
| | 146.25 | 168.75 | 2.4 | 5.2 | 3.4 | 1.6 | 0.7 | 0.2 | 0.1 | 0.0 | | 13.7 |
| S | 168.75 | 191.25 | 4.7 | 8.1 | 5.1 | 3.1 | 1.5 | 0.7 | 0.1 | 0.0 | 0.0 | 23.4 |
| | 191.25 | 213.75 | 4.2 | 8.0 | 4.8 | 2.1 | 0.6 | 0.1 | 0.0 | 0.0 | 0.0 | 19.9 |
| S-W | 213.75 | 236.25 | 2.9 | 5.0 | 3.6 | 1.3 | 0.3 | 0.0 | 0.0 | | | 13.1 |
| | 236.25 | 258.75 | 3.6 | 7.1 | 4.3 | 2.0 | 0.5 | 0.1 | 0.0 | | | 17.6 |
| W | 258.75 | 281.25 | 1.4 | 1.9 | 0.5 | 0.2 | 0.1 | 0.0 | 0.0 | | | 4.1 |
| | 281.25 | 303.75 | 0.4 | 0.2 | 0.0 | | | | | | | 0.6 |
| N-W | 303.75 | 326.25 | 0.0 | 0.0 | | | | | | | | 0.0 |
| | 326.25 | 348.75 | 0.0 | 0.0 | | | | | | | | 0.0 |
| | Sum | | 20.9 | 39.4 | 23.8 | 10.6 | 3.7 | 1.2 | 0.2 | 0.1 | 0.0 | 100.0 |

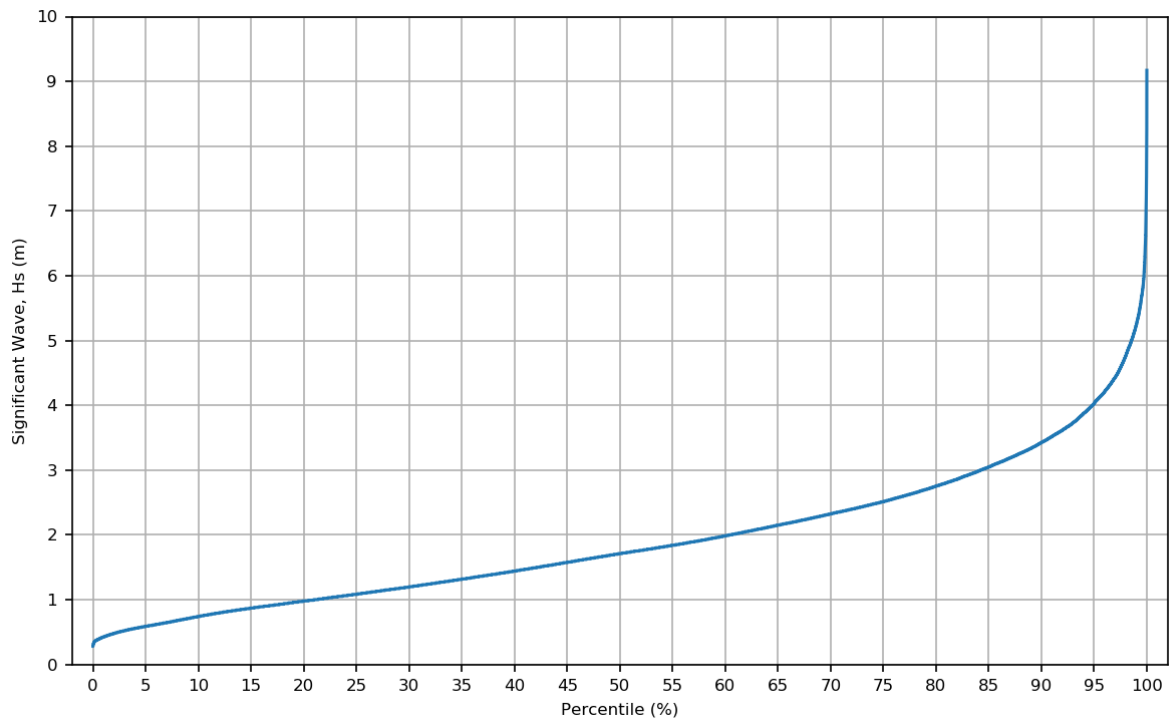

Figure 35. Wave exceedance curve for nearshore wave buoy BFK at depth of about 30 m (preliminary analysis).

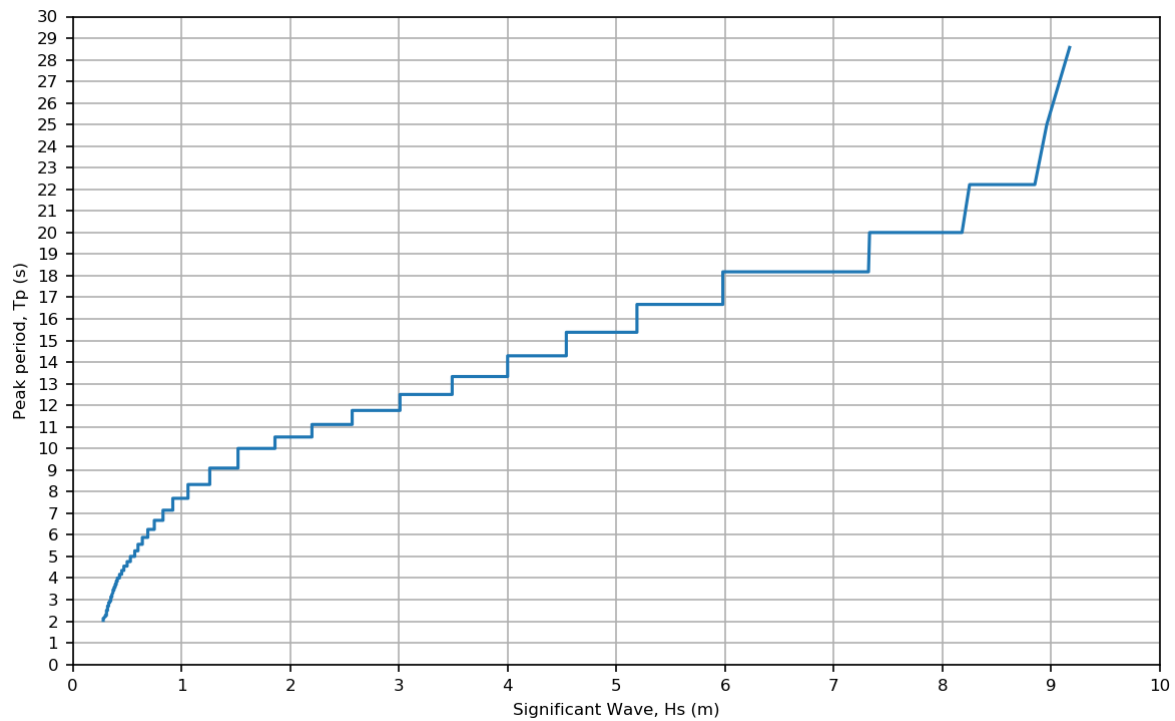

Figure 36. Peak wave period and significant wave height for nearshore wave buoy BFK at depth of about 30 m (preliminary analysis).

Table 8. Computed longshore sand transport rates for annual mean wave conditions; offshore depth = 30 m, $d_{50} = 0.35$ mm; surf zone slope 1 to 100; wave breaking coefficient = 0.6. The red numbers represent the values for Landeyjahöfn harbour.

| Nearshore wave climate | Shore normal from sea to coast (°) | LT to east (million m ³ /year) | LT to west (million m ³ /year) | Net LT (million m ³ /year) | Gross LT (million m ³ /year) |
|--|------------------------------------|---|---|---------------------------------------|---|
| Measured data | 0 | 1.05 | 0.56 | 0.49 | 1.61 |
| Wave buoy BFK (2015-2020) | 2.5 | 1.05 | 0.71 | 0.34 | 1.76 |
| | 5 | 1.05 | 0.85 | 0.2 | 1.9 |
| | 8.5 | 1.02 | 1.02 | 0 | 2.04 |
| | 10 | 1.01 | 1.1 | -0.1 | 2.1 |
| Computed wave data of location 5 based on DHI (Figure 5) | 0 | 1.06 | 0.83 | 0.23 | 1.89 |
| | 2.5 | 1.12 | 0.88 | 0.24 | 2.0 |
| | 5 | 1.2 | 0.9 | 0.3 | 2.1 |

3.3 Analysis of sedimentation in the harbour

It is not uncommon that harbour entrances and approach channels suffer from various sedimentation issues due to both currents and waves causing navigation problems for ships entering the harbour. The annual sedimentation rate is strongly related to the physical and environmental conditions and the geometric configuration of the harbour entrance. Wind, tide- and wave-induced flows and stirring of sediments have an important role when the basin is situated along a sea or a large-scale lake. The deposition of sand inside the harbour entrance, basin and the approach channel is caused by the following processes:

- inflow of suspended sediment (clay, silt, sand) during tidal filling of the harbour basin in conditions with currents and combined currents and waves;
- exchange of suspended sediment (clay, silt, sand) due to horizontal circulation flows in harbour entrance;
- inflow of suspended sediment (clay, silt and sand) due to horizontal near-bed flows generated by fluid density differences (fresh/brackish water interaction);
- inflow of suspended sediment due to wave asymmetry effects;
- trapping of sand in approach channel due to flow velocity reduction in deeper channel;
- wind-blown sand entering the basin due to wind from west and east (maximum up to 5000 m³ per year).

The sedimentation rates estimated by DHI in the pre-construction phase of the harbour (Chapter 2.2.6) have proven to be significantly underestimated. Despite the negative impact on harbour utilization caused by the sedimentation issues and roughly 10 years of valuable post-construction bathymetric data collected, a re-evaluation of long-term sedimentation rates has not been performed to date. Therefore, the consortium conducted a preliminary analysis of sedimentation in order to produce updated sedimentation estimates taking into account limited analysis of available data.

3.3.1 Bathymetry schematization

As outlined in Chapter 2, many bathymetry maps of the Landeyjahöfn harbour are available. Three typical bathymetry maps with shoaling regions are shown in Figure 37. Typical depths in the shoaling regions around the tips of the breakwater are 5 to 6 m to CD (6.5 to 7.5 m to mean sea level). As indicated in Chapter 2, proper analysis of deposition patterns and volumes as a function of space and time and the effect of storm events in combination with the available dredging records has not yet been performed.

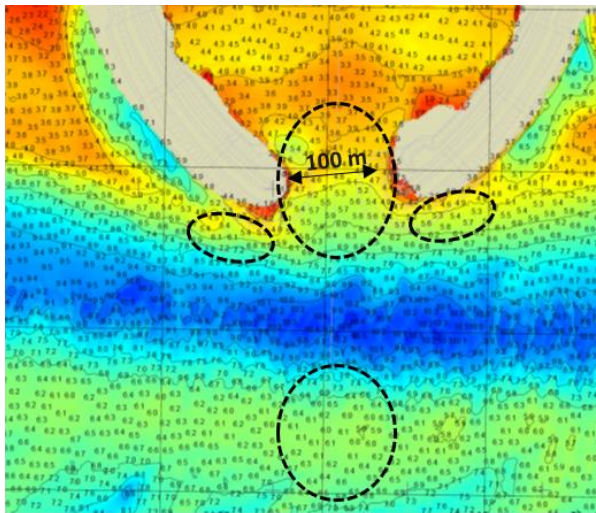

1 oct 2009

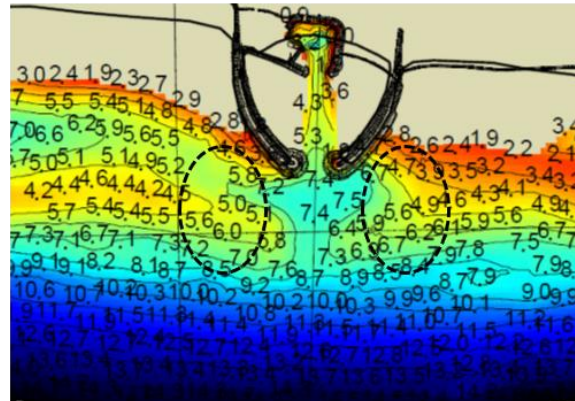

29 July 2014

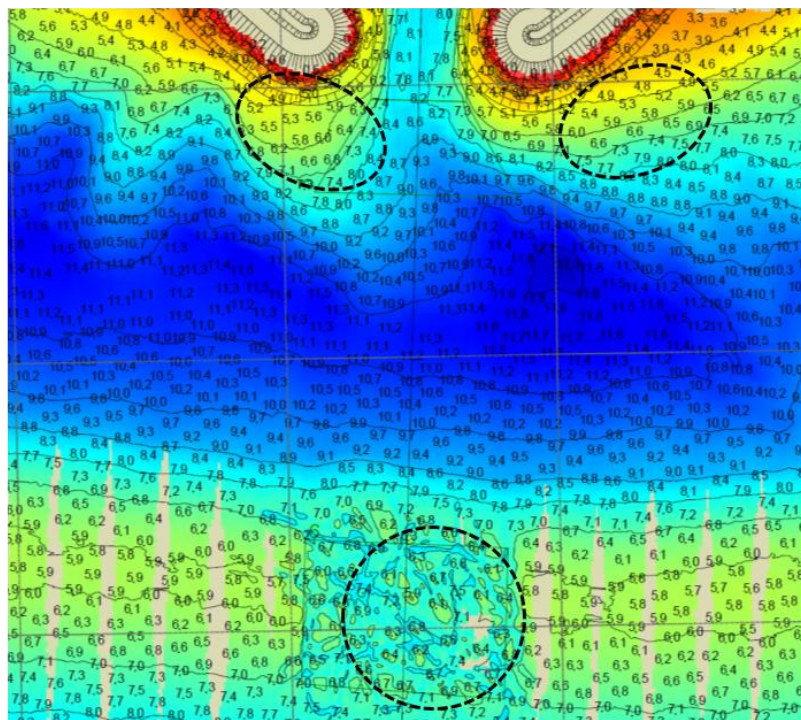

9 May 2019

Figure 37. Bathymetry maps from 2009, 2014 and 2019. A composite figure from bathymetric surveys performed by IRCA on October 10, 2009, July 29, 2014 and May 9, 2019.

3.3.2 Prediction method and input data

The deposition of sand in and near harbour entrances can be estimated by the model SEDHAR-SAND. The model expressions are described in Annex A for clarification. The model computes sand concentrations and transport of sand in approaching flow including wave stirring of sand for monthly-averaged conditions. Based on this and the geometrical dimensions of the entrance and approach channel (Figure 38), the monthly-averaged deposition volumes in the shoaling regions are computed.

The input data are shown in Table 9. The most important parameters are:

- harbour basin area $\cong 100,000 \text{ m}^2$; entrance width $\cong 100 \text{ m}$; water depth entrance $\cong 6.5 \text{ m}$;
- sand diameter 0.35 mm ; settling velocity = 0.03 m/s ; mud concentration = 50 mg/l (winter) to 10 mg/l (summer);
- seasonal mean significant wave height in the range of 1 m (summer) to 2.5 m (winter).

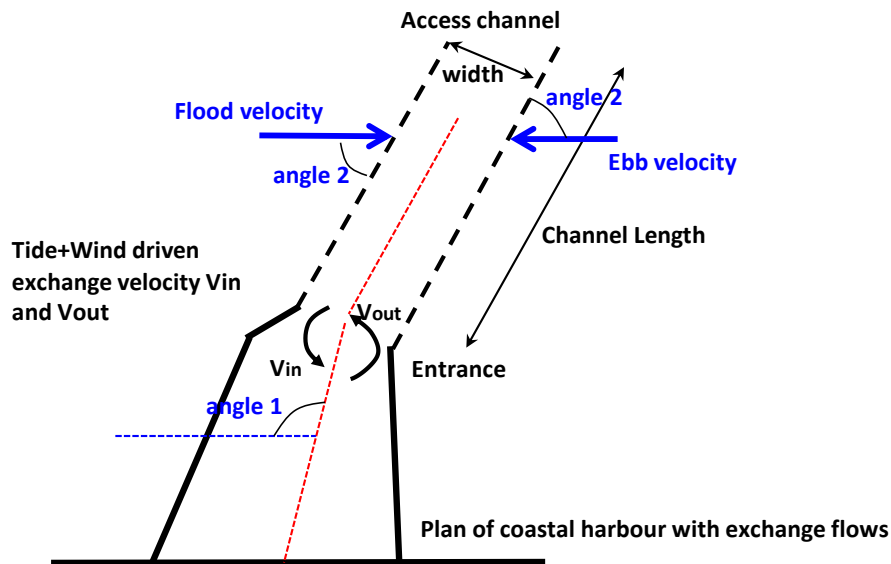

Figure 38. Schematization of deposition processes in harbour entrance and approach channel.

Table 9. Input data of SEDHAR-SAND model.

| | | |
|---|--|------------------------------|
| Length of harbour entrance | | 200 (m) |
| Width of harbour entrance (Be) | | 100 (m) |
| Angle 1 of entrance axis with ebb velocity (<i>between 0 and 180 degrees, see sketch on right</i>) | | 90 (degrees) |
| Annual-averaged water depth in harbour entrance to MSL (he) | | 6.5 (m) |
| Area of harbour basin | | 100000 (m ²) |
| Annual averaged water depth in basin | | 5 (m) |
| Length of access channel | | 100 (m) |
| Width of access channel | | 100 (m) |
| Depth of access channel below surrounding bed | | 2 (m) |
| Angle 2 of axis channel axis with river flow (<i>between 0 and 90 degrees, see sketch on right</i>) | | 90 (degrees) |
| Tidal range (<i>if no tide: tidal range = 0</i>) | | 2.5 (m) |
| Tidal period (<i>if no tide: duration = 12 hours</i>) | | 12 (hours) |
| Duration flood (<i>if no tide: duration= 12 hours</i>) | | 6 (hours) |
| Duration ebb (<i>if no tide: duration= 0 hours</i>) | | 6 (hours) |
| Maximum density difference outside-inside basin (range of 0 to 3 kg/m ³) | | 0.1 (kg/m ³) |
| Annual-averaged discharge through harbour entrance due to pump intake inside harbour | | 0 (m ³ /s) |
| Annual-averaged fresh water discharge into basin (small river/drainage channel) | | 0 (m ³ /s) |
| d50 of sand fraction | | 0.00035 (m) |
| d90 of sand fraction | | 0.0005 (m) |
| Percentage of mud/silt fraction of bed material | | 0 (percentage) |
| Settling velocity of suspended mud-clay fraction (5 to 20 micron) | | 0.0005 (m/s) |
| Settling velocity of suspended silt fraction (20 to 60 micron) | | 0.002 (m/s) |
| Settling velocity of suspended sand fraction (> 60 micron) | | 0.03 (m/s) |
| Fluid density | | 1025 (kg/m ³) |
| Sediment density | | 2650 (kg/m ³) |
| Kinematic viscosity | | 0.000001 (m ² /s) |
| Bed Roughness | | 0.02 (m) |
| Dry bulk density silt and sand (constant value) | (=1600 kg/m ³) | 1600 (kg/m ³) |
| Dry bulk density mud/clay (constant value) | (=1200 kg/m ³ for mud/clay) | 1200 (kg/m ³) |

| Month | To MSL | To MSL | To MSL | Depth-averaged flood velocity outside of entrance (m/s) | Depth-averaged ebb velocity outside (U-ebb) (m/s) (Vebb=0 if no tide) | Effective Sig wave Height outside entrance (m) (minimum value=0.01 m) | Peak wave period (s) | Duration of waves and flow (days) | |
|--------|--|---|--|---|---|---|----------------------|-----------------------------------|----|
| | Time-averaged Water depth outside entrance (tide-averaged) (m) | Time-averaged Water depth in entrance (tide-averaged) (m) | Time-averaged Water depth in basin (tide-averaged) (m) | | | | | | |
| | U-flood (m/s) | U-ebb (m/s) | U-ebb (m/s) | | | | | | |
| 1-Jan | 7 | 6.5 | 5 | 5 | 1 | 1 | 2.5 | 10 | 31 |
| 2-Feb | 7 | 6.5 | 5 | 5 | 0.9 | 0.9 | 2 | 9 | 28 |
| 3-Mar | 7 | 6.5 | 5 | 5 | 0.9 | 0.9 | 2 | 9 | 31 |
| 4-Apr | 7 | 6.5 | 5 | 5 | 0.8 | 0.8 | 1.8 | 8 | 30 |
| 5-May | 7 | 6.5 | 5 | 5 | 0.8 | 0.8 | 1.8 | 8 | 31 |
| 6-Jun | 7 | 6.5 | 5 | 5 | 0.7 | 0.7 | 1.5 | 7 | 30 |
| 7-Jul | 7 | 6.5 | 5 | 5 | 0.7 | 0.7 | 1.5 | 7 | 31 |
| 8-Aug | 7 | 6.5 | 5 | 5 | 0.8 | 0.8 | 1.8 | 8 | 31 |
| 9-Sep | 7 | 6.5 | 5 | 5 | 0.8 | 0.8 | 1.8 | 8 | 30 |
| 10-Oct | 7 | 6.5 | 5 | 5 | 0.9 | 0.9 | 2 | 9 | 31 |
| 11-Nov | 7 | 6.5 | 5 | 5 | 0.9 | 0.9 | 2 | 9 | 30 |
| 12-Dec | 7 | 6.5 | 5 | 5 | 1 | 1 | 2.5 | 10 | 31 |

3.3.3 Predicted deposition volumes

The predicted annual (deposition) volume of sand passing the harbour entrance is on the order of 100,000 m³/year, see Table 10. Most of this sand will be deposited in the entrance area and the basin area adjacent to the entrance. Assuming a total settling area of 30,000 m², the deposition layer of sand is on the order of 3 m per year.

The predicted deposition volume of mud in the harbour basin is about 15,000 m³/year based on estimated mud concentrations in the range of 10 to 50 mg/l outside the entrance. The deposition of fines (mud, silt and fine sand) will occur all over the harbour basin, whereas the deposition of the coarser sand fractions mostly occurs in the entrance area.

The deposition volume of sand in the harbour entrance area is only a fraction of the total volume of sand passing the cross-section normal to the harbour entrance, which is in the range of 1 to 2 million m³ per year.

Deposition volumes for the channel area just outside the harbour entrance can only be given as very crude estimates with error ranges of ±50% (Table 10), as it highly depends on the dredging frequency. The (channel) area just outside the entrance is dominated by migrating shoals, see Figure 37. If this area of about 100x100 m² is deepened by 1 m creating a volume of 10,000 m³, the sand filling time is of the order of 3 days in winter and 15 days in summer. If the depth of this area is increased to 100 m

creating a deep settling area (synonymous to continuous dredging), the annual infill volume of sand goes up to 0.6 million m³ per year. Similarly, the creation of large pre-dredged settling areas/pits on the flanks of both breakwaters is not meaningful given the rapid infill rates. Almost continuous dredging of about 0.6 million m³ per year is required to keep these areas open. In practice, this means that dredging is required after each storm event with waves higher than about 3 m. This may also apply to the channel passage through the outer bar.

Available dredging records show total annual values of 0.2 to 0.6 million m³ per year. The estimated deposition values of Table 10 are in reasonable agreement with the dredging volumes reported by the IRCA.

Earlier studies by DHI (2006; 2007) estimate an annual deposition volume of sand as 30,000 m³/year (entrance width of 90 m, Table 3) for the harbour basin, including the entrance area. This estimate is not realistic given the annual longshore transport volume of 1 to 2 million m³ of sand and the dynamic morphological system around Landeyjahöfn harbour. In comparison, estimates made by the consortium of sand deposition in the same area are around 95,000 m³/year (Table 10). Additionally, a rough estimate of fine sediments inside the harbour was estimated as 4,400 m³ per year by DHI (Chapter 2.2.6) compared to 15,000 m³/year by the consortium (Table 10).

No regular dredging volume was estimated at the outer bar. DHI however recommended to include the possibility of dredging about 80,000 m³ through the bar after unfortunate combinations of storms and extreme sediment discharge in the Markarfljót river which are rare events (DHI, 2007; IRCA, 2006). Further dredging due to sedimentation was not discussed, including for the harbour entrance, suggesting that equilibrium sedimentation in the entrance area would not pose a significant problem.

In the 2013 DHI report, discussions are provided on the combination of consistent easterly waves from the opening of the harbour until the end of 2010 (giving rise to westward littoral transport) and the eruption of the Eyjafjallajökull volcano in April of 2010. DHI concludes that due to the combination of these events, it is impossible to verify their deposition volume estimates from the previous studies. However, it is now clear that previous studies severely underestimated the total deposition volumes.

Table 10. Predicted annual deposition volumes.

| Shoaling areas | Width (m) | Length (m) | Depth below surrounding bed (m) | Water depth to mean sea level (m) | Annual deposition volume (m ³ /year) | |
|---------------------------------------|--------------|---------------|---------------------------------------|---|--|--------|
| | | | | | Sand | Mud |
| Harbour basin (inner area) | 300 | 200 | | 4 to 6 | 10,000 | 15,000 |
| Entrance area of harbour basin | 100 | 200 | 1 | 6 to 7 | 85,000 | 0 |
| Approach channel adjacent to entrance | 100 | 100 | 1 | 6 to 7 | >100,000 | 0 |
| Approach channel through outer bar | 100 | 200 | 1 | 6 to 7 | >100,000 | 0 |
| Totals | | | | | >300,000 | |

4 Assessment of implemented mitigation measures

In response to the severe sedimentation problems observed following the opening of the Landeyjahöfn harbour in 2010, implementation of mitigation measures was required and have continued to date. These problems were not foreseen in the design phase of the harbour due to underestimation of sedimentation rates, as previously discussed in Chapter 3.3.3. The navigational issues were compounded by the fact that the expected new ferry was not taken into operation until June 2019. Harbour design took into account a new ferry with smaller draught, more suitable for periods of accumulated sedimentation that were expected between necessary maintenance dredging. In the following chapter, a review and assessment are provided on mitigation measures which have been implemented at the Landeyjahöfn harbour to date.

4.1 Implementation of new ferry

Given the severely restricted operational efficiency of the old ferry despite extensive, costly maintenance dredging efforts, the realization of a new ferry can be considered a mitigation measure for increasing harbour utilization. Although the new ferry has only been in operation since June 2019, an initial assessment of the efficiency of the new ferry was made by the consortium.

Preliminary analysis of the limited data that were provided for the evaluation regarding utilization of the harbour suggest that fewer trips have been cancelled with the new ferry compared to its predecessor. This is especially true for the winter months. For example, the data suggest that in January and February of 2013 the old ferry did not have a single trip to Landeyjahöfn harbour but used the alternative harbour in Þorlákshöfn instead. During the same months in 2020, the total number of trips were far greater than in 2013, with over twice as many trips taken in total and about 70% of the trips were made to Landeyjahöfn harbour. Data from the IRCA suggest that for the period July 2019 to May 2020 the utilization rate of Landeyjahöfn harbour was about 90% while for the same months during the years 2012-2013 the utilization rate was less than 70%. It is important to note that analysis of differences in sedimentation, weather and waves between the two time periods have not been performed. Furthermore, some suggestions have been made that there was less sedimentation in the harbour during the winter of 2019-2020 compared to previous years. However, further bathymetric analysis is needed to assess these annual variations. A longer operational period for the new ferry is also needed for further and more detailed analysis of the utilization rate of the harbour.

Despite the preliminary analysis suggesting improved utilization of the harbour with the new ferry, it is clear that this improvement alone is not sufficient, even with continued maintenance dredging. For the harbour in its current state, utilization of other improvement measures is necessary to increase harbour utilization to an acceptable level.

4.1.1 Ferry specifications

The old ferry has a length of about 71 m, beam of 16 m, maximum draught of 4.3 m and a design draught of 4 m. Although the magnitude of sedimentation at and near the harbour entrance was not known for certain during the harbour design phase, it was nevertheless expected that the old ferry's draught would be too deep for the expected navigational conditions. High waves during times when the draught has not been a limiting factor have furthermore limited safe navigational conditions and the overall utilization of the Landeyjahöfn harbour. As a general guide, an operational wave height of 2.5 m was used for the old ferry.

During the harbour design phase, a new ferry was proposed with an expected length of about 45 m, a beam of 12 m and a draught of 3 - 3.5 m (Viggosson, Jónsdóttir, Sigurðarson, & Bernóðusson, 2005). The new ferry was intended to accommodate expected depths in and near the harbour entrance with limited need for maintenance dredging. Due to the financial crises of 2008, construction of the new ferry was put on hold and the old ferry was used until June of 2019 when the new ferry was finally put into service with the hope of significantly increasing the utilization of the harbour. The new ferry has a length of nearly 72 m, beam of about 15 m, maximum draught of 3 m and design draught of about 2.85 m. The new ferry is significantly larger than what was proposed during the harbour design phase, both in terms of length and beam, resulting in a size which is similar to the old ferry but with about 30% less draught. Design operational specifications of the new ferry are as follows:

- 4.5 m minimum operational water depth;
- 5 m minimum water depth at the outer bar;
- 3.5 m maximum wave height with a period of about 5-12 seconds;
- 3 m/s maximum current speed perpendicular to the ship;
- 22 m/s maximum wind speed.

4.1.2 Factors limiting ferry operation

Decisions on ferry cancellations take into account multiple factors and are based on various measurements and information. These decisions are made by the ferry captains, who must make judgements based on their interpretation of the available data at any given time. According to interviews performed by the consortium during the present evaluation (Chapter 3.1), the key information utilized by ferry captains include measurements of wave height and wavelength (from the radar station and buoy BFK), measured sea levels, weather measurements (wind speed and direction) and CCTV video from the harbour. An initial assessment of the data available from this list was performed by the consortium.

Wave height

In a pre-construction study (Viggosson, Jónsdóttir, Sigurðarson, & Bernóðusson, 2005) it was concluded that based on observed navigational conditions at entrances to other harbours on the southern coast of Iceland, safe navigation through the surf zone and into the Landeyjahöfn harbour should be possible for 30-50 m long vessels operating in up to 3.5 m maximum significant wave height just outside of the surf zone. Despite the greater than expected length of the new ferry, its operational specifications with respect to wave height do fall within the range assumed in the design phase of the harbour (3.5 m maximum wave height).

In addition, preliminary wave analysis performed by the consortium (Figure 35) for the current buoy BFK (Figure 4) shows a wave exceedance of around 10% for 3.5 m significant wave height. This indicates that for the design wave height for safe navigation (3.5 m), 90% of the time wave height should not be a limiting factor for navigation into the harbour. The wave exceedance increases to 25% for a significant wave height of 2.5 m. Although the above-mentioned wave analyses indicate that wave height is likely to be a significant factor limiting ferry operation, this is difficult to determine due to the lack of adequate analysis of harbour utilization information. Preliminary review of operational data from 2019-2020 shows that ferry cancellations have occurred when wave heights were below 3.5 m. However, these cancellations could be due to other limiting factors and not the wave height itself. Accumulation, review and analysis of the operational data could give important insight into the most frequent limiting factors for the ferry.

Current speed

The estimated tidal current speeds modelled by DHI (2007) are an order of magnitude lower than the speeds defined for safe navigation in the ferry specifications. Surface currents due to wind and waves, as indicated by radar measurements, are also lower than the design criteria for safe navigation. Therefore, surface current speed is unlikely to be a main determining factor causing navigational problems.

Weather

Weather can have both a direct and indirect influence on the decision-making process for ferry cancellations. High wind speeds have a direct, detrimental effect on navigational conditions at the harbour. However, measured wind speeds at Landeyjahöfn are lower than the design wind speed for safe navigation 99.5% of the time. Therefore, wind speed is unlikely to be a major factor causing navigational problems. Other weather factors, such as heavy rain, can have an indirect effect on the decision-making process regarding ferry cancellations. During heavy rain events, the radar data, which the captains believe is a useful tool to estimate conditions at the harbour mouth, can be unreliable due to noise in the measurements. This can lead to ferry cancellations due to uncertainty in radar information caused by the rain.

4.2 Maintenance dredging

The main mitigation technique for improving harbour utilization to date has been maintenance dredging. Dredging operations have been performed on a regular basis since opening of the harbour. As mentioned previously, significantly more dredged material has been removed than was originally anticipated, resulting in high operational costs. Despite the extensive dredging efforts, the harbour has nevertheless experienced significant closures.

The entrance of Landeyjahöfn harbour is situated well inside the surf zone during storm events with waves higher than about 4 m. During these conditions, high waves break on the outer breaker bar which is about 300 to 500 m seaward of the harbour entrance. Longshore currents generated by breaking waves supply large quantities of sand towards the harbour entrance. Long-term gross annual longshore transport values are in the range of 1 to 2 million m³ per year (Chapter 3.2). Sand is deposited in and near the harbour entrance area due to various processes (tidal filling, circulation flows, wave asymmetry-related transport). The annual mean deposition of sand requiring dredging operations is estimated by the consortium (Chapter 3.3) to be about 0.3 to 0.5 million m³ per year with unchanged depth targets in the dredged areas. Dredging quantities have been severely underestimated in earlier studies, as explained in Chapter 3.3.3.

According to Lund University (2018), dredging is typically initiated when the minimum depth is less than 4 m to CD in the entrance channel. After completion of dredging, depth is in the range of 6-7 m to CD. During autumn and winter seasons the wave conditions are often too severe for dredging (IRCA, 2018b). This has caused frequent closures of the Landeyjahöfn harbour and resulting diversions (totalling 2-5 months each year) of the old ferry to its alternative harbour in Þorlákshöfn (Viðarsdóttir, 2019). The new ferry has less draught and therefore the dredging needs will be reduced, but it is still important to keep adequate navigational depths for the new ferry. Some preventive dredging attempts have been made but analysis on the effectiveness of these operations has not been performed (IRCA, 2018b).

DHI has suggested that the dredging cost can be reduced considerably if the navigation channel depth would be maintained exclusively during summer months. In this scenario, the navigation channel

would be allowed to fill during the winter. The channel would fill up rapidly due to sand transport processes during autumn and winter storms causing the harbour to be closed, resulting in exclusive utilization of the Þorlákshöfn harbour. This would result in increased bypass in front of the harbour mouth during the winter months reducing the overall annual dredging need (DHI, 2013). However, this dredging strategy would significantly reduce the service of the ferry, as trip frequency would decrease due to longer travel times between Þorlákshöfn and the Westman Islands.

Another strategy for decreasing dredging needs by ships was proposed by the IRCA in 2018 by introducing a land-based dredging solution to the harbour entrance dredging problem (Figure 39). Very limited documentation regarding that proposal was provided by the IRCA for the present evaluation. Construction of this land-based solution was initiated but not completed, as it was deemed unfavourable by ferry captains. Narrowing of the harbour entrance by about 25%, as proposed in the design (DHI, 2018), would result in unsafe navigational conditions, especially during bad weather, and therefore reduce harbour utilization. This experience highlights the need for improved communication and collaboration between the IRCA and local seafarers. A successful land-based dredging method requires a design that does not affect the width of the harbour entrance.

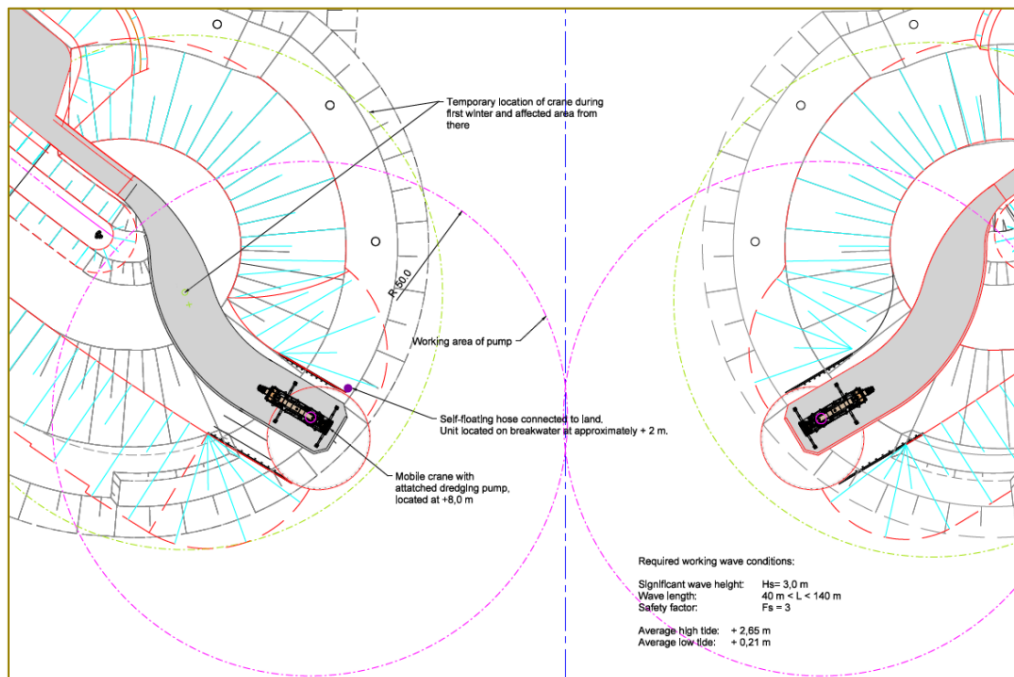

Figure 39. The harbour entrance for the proposed layout of the land-based dredging system (DHI,2018).

DHI (2018) and Lund University (2018) studied the impact of the land-based dredging system on littoral drift and deposition. DHI concluded that changes in the breakwater heads configuration would not cause substantial changes in the current and would thus not affect the littoral transport or the deposition processes in front of the harbour. Furthermore, that the dredging volume in such a system would be greater than what results from present operations, if the same navigation depth is to be maintained. Lund University agreed on the negligible influence of the breakwater head modifications on the transport and morphological evolution around the harbour entrance.

DHI suggested that a depth of 6 m be maintained in the navigational channel (instead of the 7 m that was used at the time) during the calmer parts of the year (March 16th to November 15th), and a

maximum depth of 5 m be maintained in the winter period to avoid interrupting the bypass in front of the harbour mouth (DHI, 2018). This would reduce the overall dredging volumes during the wintertime.

The safe navigation depth in the entrance was defined as 5.5 m to CD in the harbour design phase (DHI, 2007) for a ferry with a draught of 3-3.5 m. The new ferry has a maximum draught of 3 m and design draught of 2.85 m and is expected to be able to operate in 4.5 m depth in the harbour entrance. This is close to the proposed maximum depth of 5 m in the DHI proposal with the land-based dredging system. Therefore, it is important to analyse this strategy and other potential dredging strategies with regards to their impact on the utilization of the harbour, taking into account limitations of the ferry and the harsh navigation conditions between the harbour mouth and the outer bar. Such an analysis needs to be supported by a suitable analysis of the sedimentation dynamics in space and time based on the available bathymetry maps.

Limited analysis of the wave and bathymetry data and lack of analysis of harbour utilization restricts the possible assessment on future dredging operations aimed at improving the navigational conditions for the new ferry. However, the assessments on longshore transport and near-harbour sedimentation suggest that reported sedimentation in the past years indicates the extent of future sedimentation that can be expected at Landeyjahöfn harbour. The lower draught of the new ferry, however, along with other navigational improvements, may require lower maintenance dredging in the future than past dredging operations suggest. At this stage, it is not possible to assess to what extent maintenance dredging can be improved and operational needs decreased during winter months. Such assessment requires further analysis of the harsh wave climate between the harbour mouth and the bar and its effect on possible improvement measures.

4.3 Recommendations for identifying future improvement measures

The primary factors limiting ferry operation and the experience gained from implemented maintenance dredging to date must be put into context with an assessment of future sedimentation and the frequent harsh wave climate outside the harbour entrance. That context provides input into the specific questions raised in the parliamentary resolution and addresses the need for improvement in harbour utilization, as implemented mitigation methods to date have proven insufficient. Furthermore, it provides a foundation for recommendations on specific aims for the completion of an independent, comprehensive evaluation of the harbour, and helps to create a suitable roadmap towards that final goal.

Taking into account the methodology outlined above, the specific questions raised in the parliamentary resolution are addressed below:

1. *Is it possible to significantly decrease the frequency of dredging operations, or eliminate the need for dredging altogether, with improvement measures for the harbour?*

The degree of sedimentation that has been experienced since the harbour opened gives a good indication of the sedimentation that can be expected in the future for the harbour with unchanged depth targets.

In order to significantly decrease the frequency of dredging operations, a maintenance dredging schedule needs to be formulated, taking into account operational characteristics of the new ferry as well as acquired experience and analysis of harbour utilization factors. That schedule would then be compared to historical dredging operations to evaluate whether a

lower dredging frequency can be expected. Furthermore, various versions of this dredging schedule would be evaluated, taking into account additional improvement measures based on sheltering techniques. These include implementation of structures aimed at providing shelter from high waves breaking on the outer bar, with the ultimate goal of improved navigational conditions between the outer bar and the harbour entrance. The roadmap to a complete, comprehensive Landeyjahöfn harbour evaluation includes defining the appropriate prerequisites to the maintenance dredging schedule, formulating such a schedule and identifying and evaluating possible improvement measure scenarios combining dredging and sheltering mitigation techniques.

Eliminating the need for dredging completely is unlikely with the harbour in its current state. In all likelihood, elimination of dredging altogether would require a new harbour concept. This type of solution must be fully characterized and evaluated in order to determine its viability as an alternative approach in an overall comparison of possible improvement measures.

2. *If so, what would those improvement measures involve and what is their estimated cost?*

The roadmap to a complete, comprehensive Landeyjahöfn harbour evaluation includes the identification and evaluation of possible improvement measures based on sheltering techniques outside the harbour entrance and alternatively a new harbour concept aimed towards eliminating regular maintenance dredging operations as far as possible and practical. This will result in a detailed comparison of all possible improvement measures including both technical and financial factors.

3. *If such improvement measures to the harbour are not deemed viable, either due to technical or financial reasons, then what type of dredging program would be necessary to eliminate closure of the harbour and keep it operational year-round?*

At this stage in the evaluation process, it is not possible to draw definitive conclusions on the viability of possible improvement measures aimed at significantly decreasing the frequency of dredging operations or eliminate them altogether. The roadmap to a complete, comprehensive independent Landeyjahöfn harbour evaluation includes both technical evaluations and cost estimates on possible improvement measures. Furthermore, the roadmap includes an evaluation of operational data from the new ferry in current conditions where no actual improvement measures are implemented, which serves as a baseline for formulating a maintenance dredging schedule. However, it must be noted that sedimentation is not the only factor affecting safe navigational conditions and overall utilization of the harbour. Wave conditions have also proven to be significant limiting factors. Therefore, such a baseline option for future operations will not eliminate closures of the harbour.

Clearly, complete answers to the questions above cannot be provided at this stage due to lack of adequate information. Further data acquisition and analysis is required in order to draw conclusion and make decisions on future improvement measures at Landeyjahöfn harbour. However, addressing the questions in the manner above helps to identify key outstanding issues that need to be addressed, and provide the basis for a path forward.

Recommendations on specific tasks for the completion of a comprehensive independent evaluation of the harbour are provided in the roadmap described in Chapter 5.

5 Roadmap towards a comprehensive, independent evaluation

The review and assessment process employed in the present evaluation project has brought to light various information gaps that must be filled before important conclusions can be drawn regarding the future of the Landeyjahöfn harbour. Therefore, the work presented in this report is considered a preliminary evaluation providing the first steps toward a complete, comprehensive independent evaluation of the Landeyjahöfn harbour. Additional steps are required to complete the goal of fully addressing the questions raised in the parliamentary resolution. Combined, these individual steps form a roadmap towards this goal, and include the following:

1. Fill information gaps – Further data collection and analysis
2. Define baseline case for future harbour operation without improvement measures
3. Identify and examine potential improvement measures
4. Compare and assess viability of improvement measures with respect to parliamentary resolution

These individual steps are described in a more detail in the following sections.

5.1 Fill information gaps – Further data collection and analysis

An important part of the present evaluation process was identifying information gaps which restrict, at the current stage, completion of a comprehensive independent evaluation.

During review of existing data made available for the evaluation, it became clear that there are significant information gaps that need to be filled to achieve the goal of the comprehensive evaluation. Some gaps were partially filled by the consortium during the course of the present evaluation (Chapter 3). Additional gaps remain, however, which must be further evaluated with regards to their importance and at what stage in the overall process they should be addressed.

The following is a list of the primary information gaps identified along with recommended actions needed to address them:

| Category | Type of information gap | Actions |
|----------------------|---|---------|
| Ocean forcing | 1. Measurements of ocean currents (direction and speed with depth) | 3 |
| | 2. Analysis of available directional wave measurements | 1, 2 |
| | 3. Analysis of non-directional wave measurements | 2 |
| | 4. Comprehensive wave climate analysis based on all wave measurements | 2 |
| Sediment dynamics | 5. Detailed analysis of bathymetric surveys with regards to deposition patterns as a function of space and time | 2 |
| | 6. Assessment of the sediment transport dynamics, including the outer bar dynamics and causal relationships, particularly with regards to potential mitigation and improvement measures | 3 |
| Maintenance dredging | 7. Assessment of factors limiting dredging operations based on experience to date | 2 |

| | | |
|---|--|---|
| | <p>8. Assessment of the effectiveness of historical dredging operations, including preventive operations and assessment of alternative methods for future dredging operations (side cast dredging)</p> <p>9. Expected maintenance dredging schedules for the new ferry</p> <p>10. Assessment of the proposed land-based dredging technique and decision process to abandon those plans</p> | <p>2</p> <p>2</p> <p>1, 2</p> |
| Harsh wave conditions outside the harbour | 11. Investigation and assessment of possible measures to shelter the navigational area between the outer bar and harbour entrance | 1, 2 |
| Ferry operations and harbour utilization | <p>12. Documentation of operational data related to the ferry, including the perspective of its captains and officers as well as port directors for navigational conditions, primary factors limiting ferry operation and decision-making process for cancellations</p> <p>13. Documentation and analysis of harbour utilization, including factors affecting utilization</p> <p>14. Assessment of the effectiveness, usefulness and accuracy of radar measurements to provide a basis on surface currents and wave characteristics in the entrance area and within the harbour basin</p> <p>15. Assessment of the suitability of the tools that are at the ferry captains' disposal at any given time for decision-making on trip cancellations</p> | <p>1, 2</p> <p>1, 2</p> <p>3</p> <p>2</p> |

Actions to address data gaps:

- 1: Limited data collection and/or analysis performed by the consortium during the present study.
- 2: Full data collection and/or analysis required.
- 3: Assessment of the need for data collection and/or analysis required.

5.2 Define baseline case for future harbour operation without improvement measures

A baseline case needs to be determined for harbour operation with which comparisons can be made to assess possible improvement measures. As such, the baseline case would presume that no improvement measures would be implemented, and future operation would take the new ferry into account as well as some form of continued maintenance dredging. Operational constraints would be identified coherent with harbour utilization and estimated costs involved would be assessed.

Historical mitigation measures utilized in conjunction with the old ferry have proven costly and ineffective at maintaining an acceptable level of harbour utilization. Improved navigability of the new ferry could result in increased effectiveness of the current dredging measures and lower costs by decreasing the magnitude and frequency of the dredging operations. This must, however, be assessed further after more experience is gained from operation of the new ferry. Furthermore, alternatives to the historical dredging schemes can be explored to assess potential improvement in long-term effectiveness of the maintenance dredging.

5.3 Identify and examine potential improvement measures

For successful examination of possible improvement measures, a suitable methodology needs to be formulated and applied which incorporates as much available data and information as possible. The methodology can be expected to be collectively comprised of theoretical considerations, simple computations, and numerical modelling analyses.

Following further data collection and analysis, composition of a baseline case for harbour operation and formulation of a suitable examination methodology, possible improvement measures can be identified and examined in detail. Given the context of expected conditions and general aim for improvements (Chapter 4), the improvement measures are likely to fall into two concept categories:

1. Shelter concept
2. New harbour concept

The shelter concept involves implementation of structures aimed at providing shelter from high waves breaking on the outer bar, with the goal of improving navigational conditions between the outer bar and the harbour entrance. The new harbour concept, on the other hand, aims to eliminate the regular maintenance dredging operations altogether while ensuring safe navigational conditions unaffected by breaking waves on the outer bar.

Both concepts must provide solutions that will not result in severe sedimentation that may affect long-term or short-term conditions. Furthermore, both concepts may not impose unstable conditions for the improvement measure structures nor present harbour structures.

For each concept, possible measures need to be identified and examined, particularly with respect to changes in ocean current, wave climate and sediment transport and deposition in the vicinity of the harbour caused by the improvement measures. Examination of improvement measures will provide an assessment on factors affecting the navigability of the ferry, including marine conditions and sedimentation as well as the possible scouring of bed material and excessive sediment deposition. Furthermore, the examinations must include an assessment on possible long-term effects of the improvement measures on the breaker bar and other areas of importance in the vicinity of the harbour and determine if unstable conditions may result from the measures. Following the examination, a representative layout for each concept should be selected for comparison with the other concept as well as with the baseline case.

Further description is provided on the two improvement measure concepts along with potential types of individual measures that could be implemented. The following description is only intended to put the concepts in perspective based on available information and investigations to date, and do not include detailed layouts that could be examined.

5.3.1 Shelter concept

Possible improvement measures to minimize wave heights between the outer bar and the harbour entrance may include building detached breakwaters near the outer bar, providing a large enough gap for the ferry to sail safely through. Such breakwaters could reduce the wave height near the harbour entrance. A similar solution has been proposed as a radical solution by DHI (2013) to promote sedimentation of sand on both sides of the harbour, reducing the dredging need at the mouth of the harbour (Figure 26). This option was found to have positive effects (DHI, 2013).

The IRCA have performed a preliminary study on wave reduction with detached breakwaters (Figure 40) for improving navigation (IRCA, 2015b; 2015d; 2016). The preliminary findings indicate that a

significant reduction in wave height may be obtained, suggesting that the sheltering concept should be further studied in detail with regards to wave, sedimentation, navigation and utilization of the harbour.

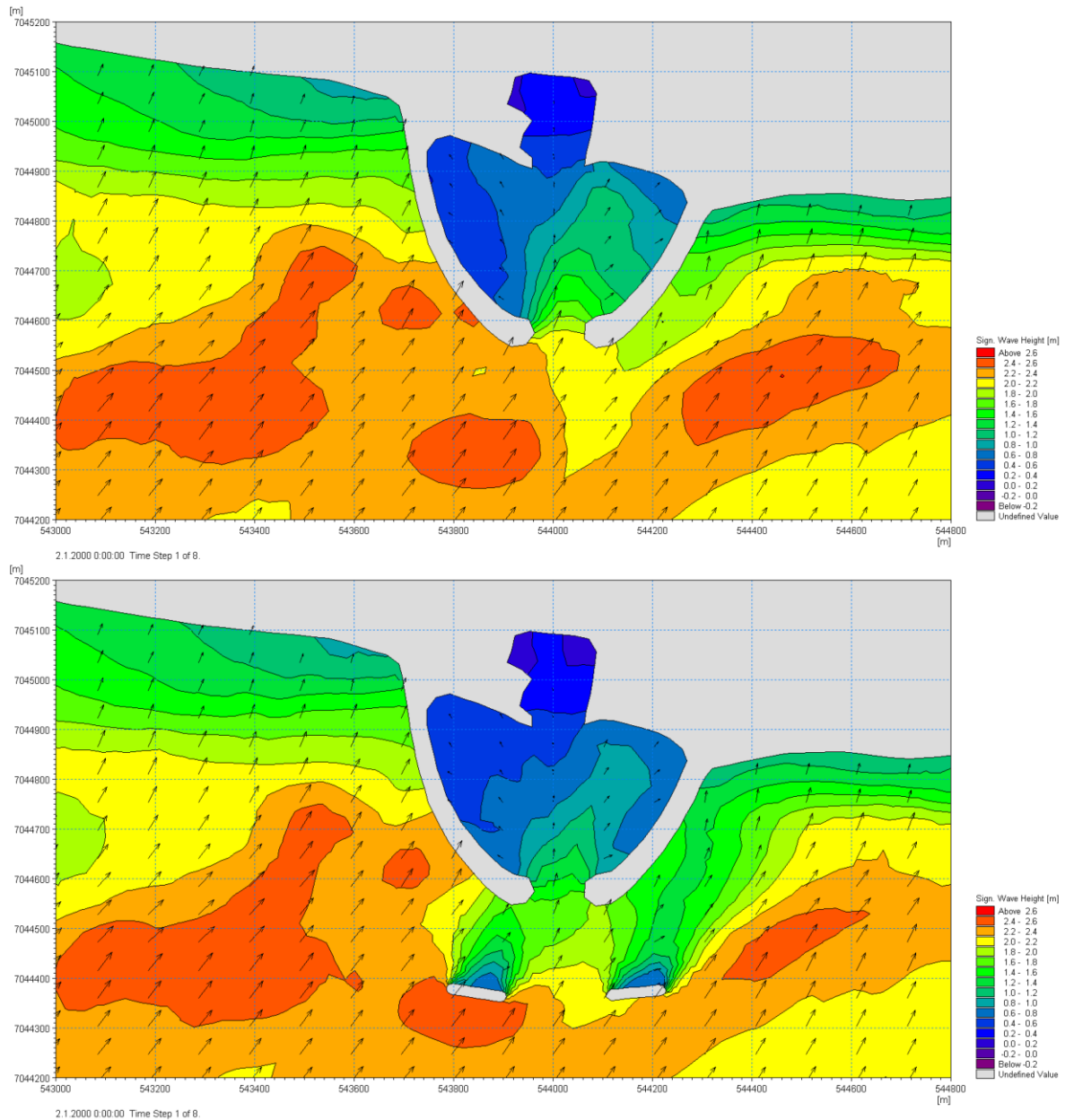

Figure 40. Wave height with (lower) and without (upper) detached breakwaters for conditions on March 7, 2010 at 18:00 (IRCA, 2015d).

Building detached breakwaters on the crest of the outer bar may be problematic due to the movement of the bar itself. The dynamic nature of the outer bar needs to be investigated further with respect to the causal relationship of contributing factors to its movement and potential changes in response to structures placed on or near the bar. It is also possible that sedimentation will occur at the breakwaters and shoals may form in the gap between the two breakwaters. This must be investigated further and taken into account as needed during possible design of such structures to prevent the sedimentation to affect the navigation line for the ferry.

These and other possible improvement measures aimed at providing shelter outside the harbour entrance for improved navigational conditions must be identified and examined during future stages in the continued evaluation process.

The shelter concept will still require maintenance dredging. To date, only traditional dredging methods have been implemented in Landeyjahöfn harbour. Other alternative methods do, however, exist and could prove to be significantly more effective. For example, a side-cast dredging system may be effective. With side-cast dredging, dredged sediments are immediately jettted overboard using a long boom on the downdrift side of the channel. With sheltering, such system would be less affected by the harsh wave climate outside the harbour entrance. Additionally, the IRCA has previously proposed and started construction of a land-based dredging solution to the harbour entrance dredging problems, and later abandoning the concept due to unacceptable narrowing of the harbour entrance in the opinion of the ferry captains, as previously discussed in Chapter 4.2. Alternative dredging methods were not assessed as part of this evaluation. However, it is worthwhile to invest in further assessment of these methods in combination with the sheltering concepts.

5.3.2 New harbour concept

In all likelihood, the need for regular maintenance dredging will not be eliminated without considering a very drastic modification to the harbour area, leading to a new harbour concept. Such a concept must consider of course other factors affecting safe navigation of the ferry. An example of such a concept is the construction of a new island-harbour south of the current harbour, at a greater depth and beyond the outer bar. Suitable depths may possibly be around 15 m, but this needs to be investigated further. Such an island-harbour would be connected to the present harbour by a bridge.

The feasibility and design would have to be investigated further, but the overall aim would be to have the longshore sand transport pass under the bridge. The present harbour basin may accumulate sand, and even end up being filled with sand. The new island-harbour, including breakwaters and entrance, must be designed in such a manner that waves outside the harbour would not limit the utilization of the harbour allowing the ferry to be safely navigated to the harbour in most weather conditions.

During the planning stages of Landeyjahöfn harbour, an option for an island-harbour layout (Figure 41) was evaluated by the IRCA. It was determined to be not a viable option at the time (VSÓ ráðgjöf, 2008), the reason being high construction costs, higher risk during construction and higher operating cost than for the alternative design, which is the one that was built.

Further investigations into such a drastic solution to the sedimentation problem may provide valuable input to the comparison of long-term costs of different improvement measures. These investigations would, however, have to include the study of all factors affecting navigational conditions including the wave climate outside the harbour entrance. Such studies would benefit from all data and information collected since the pre-construction phase of the Landeyjahöfn harbour, as well as the expected further data collection and analysis recommended in the present evaluation (Chapter 5.1).

These and other possible improvement measures aimed to eliminate the need for regular maintenance dredging and providing improved navigational conditions must be identified and examined during the continued independent evaluation process.

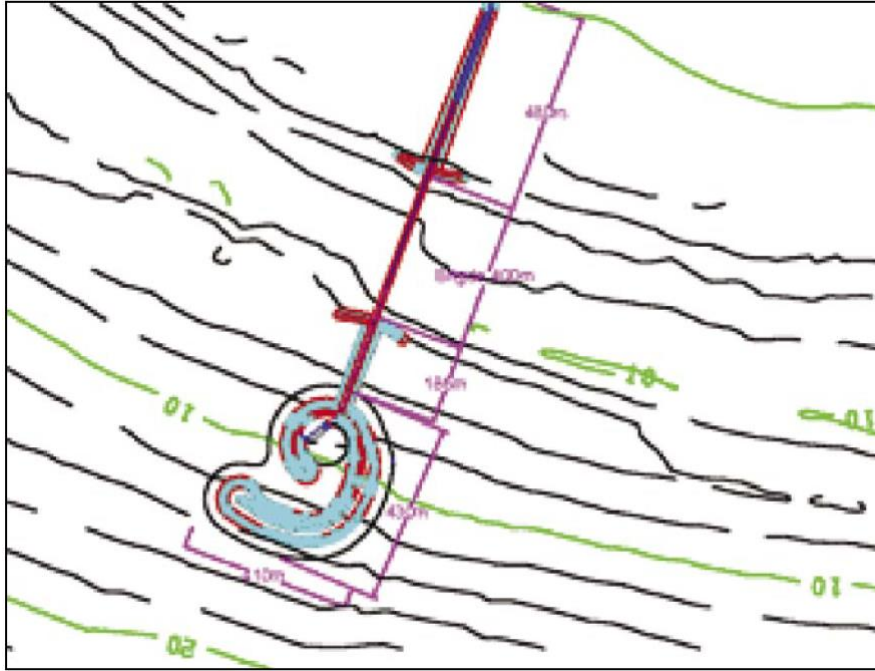

Figure 41. An idea for an island-harbour layout from the planning stages of Landeyjahöfn harbour.

5.4 Compare and assess viability of improvement measures

Once representative layouts of improvement measures have been selected for each concept category, comparison of those layouts as well as comparison with the baseline case can be performed. The comparisons will follow a common methodology considering all aspects of harbour utilization, operational constraints and cost estimates, accounting for a clear set of improvement goals.

As such, the safety of navigational conditions is assessed for both concept categories as well as the baseline case. This applies especially to the area between the outer bar and the harbour entrance for the baseline case and shelter concept. Favourable conditions resulting from the shelter concept require wave height to be decreased significantly between the outer bar and harbour entrance, and sedimentation in that area as well as inside the harbour to be manageable within the draught constraints of the new ferry. For the new harbour concept, the conditions along the navigational line towards the new harbour should be assessed in detail.

For both improvement concepts, care must be taken to ensure they do not cause unexpected new problems relating to the harbour utilization, e.g. unstable breakwater conditions and increased current velocities resulting perhaps in unfavourable scouring conditions.

A comparison of cost estimates for both improvement concepts and the baseline case is a key element in the improvement measure assessments. Cost comparisons may be weighed against predicted benefits from each strategy.

A clear comparison on improvement strategies, weighing pros and cons, should provide complete answers to the questions raised in the parliamentary resolution and allow for recommendations as to which improvement measures have the highest likelihood to succeed.



6 Concluding remarks

The evaluation framework defined by the Ministry called for an independent preliminary evaluation of Landeyjahöfn harbour with emphasis on extracting available information through a review and assessment process. This process has provided a good overview of available measurements, which appear to be of good quality and encompass most key natural processes affecting the conditions near the harbour. Furthermore, important information gaps were identified, including measurements and analyses relating to ocean forcing and sedimentation processes, historical maintenance dredging measures and harbour utilization. Some gaps were partially filled during the course of the present evaluation, however additional gaps remain which must be addressed to complete a comprehensive evaluation.

An assessment of applied mitigation measures to date, primarily implementation of a new ferry and maintenance dredging, has allowed for recommendations for identifying future improvement measures. Additionally, a roadmap has been realized defining additional steps required to complete a comprehensive independent evaluation of Landeyjahöfn harbour and realize the ultimate goals of the parliamentary resolution.

References

- Dally, W.R., & Osiecki, D.A. (1994). *The role of rollers in surf zone currents*. 24th ICCE, Kobe, Japan.
- Davies, A.G., & Villaret, C. (1997). *Oscillatory flow over rippled beds*. In J.N. Hunt (ed.), *Gravity Waves in Water of Finite Depth: Chapter 6* (pp. 215-254). Advances in fluid mechanics, Computational Mechanics Publications.
- Davies, A.G., & Villaret, C. (1998). *Wave-induced currents above rippled beds*. In *Physics of estuaries and coastal seas*, edited by J. Dronkers and M. Scheffers (pp. 187-199). Balkema: Brookfield.
- Davies, A.G., & Villaret, C. (1999). *Eulerian drift induced by progressive waves above rippled and very rough bed*. *Journal of Geophysical Research*, Vol. 104, No. C1, (pp. 1465-1488).
- DHI. (2006). *Sediment Transport and Morphology. Phase 1*.
- DHI. (2007). *Sediment Transport and Morphology. Phase 2*.
- DHI. (2008). *Bakkafjara. Wave set-up and erosion depth along breakwaters*.
- DHI. (2010). *Bakkafjara. Technical Note on the Development during Autumn 2010*.
- DHI. (2013). *Landeyjahöfn. Further Investigations. Additional analysis and modelling*.
- DHI. (2018). *Sedimentation in entrance of Landeyjahöfn. Assessment of proposed land based dredging system. Impact on the littoral drift and the transport and settling of sand*.
- Grasmeijer, B.T. (2001). *Sand transport and morphology in the surf zone of Egmond, The Netherlands*. Doc. Thesis, Dep. of Physical Geography, University of Utrecht, The Netherlands (in preparation).
- Grasmeijer, B.T., & Van Rijn, L.C. (1998). *Breaker bar formation and migration*. Proc. ICCE., (pp. 2750-2758). Copenhagen, Denmark.
- Houwman, K.T., & Ruessink, B.G. (1996). *Sediment transport in the vicinity of the shoreface nourishment of Terschelling*. Dep. of Physical Geography. Univ. of Utrecht, The Netherlands.
- Icelandic Meteorological Office. (2020a). IMO data bank, delivery no. 2020-06-30/HI03.
- Icelandic Meteorological Office. (2020b). IMO data bank, delivery no. 2020-06-30/HI04.
- Icelandic Meteorological Office. (2020c). IMO data bank, delivery no. 2020-06-30/HI05.
- Icelandic Meteorological Office. (2020d). IMO data bank, delivery no. 2020-06-30/HI06.
- Icelandic Meteorological Office. (2020e). IMO data bank, delivery no. 2020-06-30/HI07.
- Icelandic Meteorological Office. (2020f). IMO data bank, delivery no. 2020-06-30/HI08.
- IRCA. (2006). *Ferjuhöfn við Bakkafjöru. Áfangaskýrsla um rannsóknir og tillögur*.
- IRCA. (2015a). *Comparison between the directional Waverider buoy, MIKE21 SW, the Bakkafjara east buoy and the radar*.
- IRCA. (2015b). *Minnisblað - Ytri garðar við Landeyjahöfn. Skjóláhrif ytri garða við Landeyjahöfn*.
- IRCA. (2015c). *Sand transport in Landeyjahöfn; volume calculations*.
- IRCA. (2015d). *Technical Memo – Detached Breakwaters outside Landeyjahöfn. Shelter provided by detached breakwaters outside Landeyjahöfn*.



- IRCA. (2015e). *Technical Memo – Waves outside Landeyjahöfn.*
- IRCA. (2016). *Minnisblað - Landeyjahöfn ytri garðar. Mike21 SW keyrslur fyrir Landeyjahöfn með og án ytri garða.*
- IRCA. (2017a). *Minnisblað – Dýptarbreytingar í Landeyjahöfn vetur 2015-16. Viðhaldsdýpkun í Landeyjahöfn.*
- IRCA. (2017b). *Minnisblað – Dýptarbreytingar í Landeyjahöfn vetur 2016-17. Viðhaldsdýpkun í Landeyjahöfn.*
- IRCA. (2017c). *Technical Memo - Landeyjahöfn. Evaluation of return periods of significant wave height and sea level.*
- IRCA. (2018a). *Memo – Timeseries of seabed elevation in Landeyjahöfn in the period 2016-18.*
- IRCA. (2018b). *Sedimentation in Landeyjahöfn. Analysing the sedimentation in the harbor entrance in Landeyjahöfn based on real measurements.*
- IRCA. (2018c). *Memo – Sediment grain size at Landeyjahöfn 2015-2018. Sediment gradation and grain size in bedsamples from Landeyjahöfn 2015-2018.*
- IRCA. (2019). *Memo – Dredging activities in Landeyjahöfn 2018.*
- IRCA. (2020). *Landeyjahöfn Sandflutningsgeta 2010-2020. .*
- Isobe, M., & Horikawa, K. (1982). *Study on water particle velocities of shoaling and breaking waves. Coastal Engineering in Japan, Vol. 25.*
- ITA. (2012, November 27). *Straummælingar við Landeyjahöfn.* Retrieved from <https://www.samgongustofa.is/um/frettir/siglingafrettir/nr/469>
- Lund University. (2013a). *Comments on the revised investigations performed by DHI regarding Landeyjahöfn harbor.*
- Lund University. (2013b). *TVRL comments on the revised DHI report 11812013_landeyjahöfn_15.02.13_part regarding Landeyjahöfn harbor.*
- Lund University. (2018). *Influence of modified breakwater heads on the sediment transport and deposition at Landeyjahöfn, Iceland .*
- Morgunblaðið. (2020). *Sandfjallið úr Landeyjahöfn. Grein eftir Sigtrygg Sigtryggsson, 16. janúar 2020.*
- Svendsen, I.A. (1984). *Mass flux and undertow in the surf zone. Coastal Engineering, Vol. 8, (pp 347-365).*
- Van Rijn, L. C. (1990, 2011). *Principles of fluid flow and surface waves in rivers, estuaries and coastal seas.* Aqua Publications, Nederland (www.aquapublications.nl).
- Van Rijn, L. C. (1993, 2006). *Principles of sediment transport in rivers, estuaries and coastal seas.* Aqua Publications, Nederland (www.aquapublications.nl).
- Van Rijn, L. C. (1997). *Cross-shore sand transport and bed composition.* Coastal Dynamics, Plymouth, England, (pp 88-98).
- Van Rijn, L. C. (1998). *The effect of sediment composition on cross-shore bed profiles.* ICCE. Copenhagen, Denmark.

- Van Rijn, L. C. (2006,2012). *Principles of sedimentation and erosion engineering in rivers, estuaries and coastal seas*. Aqua Publications, Nederland (www.aquapublications.nl).
- Van Rijn, L. C. (2007a). *Unified view of sediment transport by currents and waves, I: Initiation of motion, bed roughness and bed-load transport*. Journal of Hydraulic Engineering, ASCE, Vol. 133, No. 6, (pp 649-667).
- Van Rijn, L. C. (2007b). *Unified view of sediment transport by currents and waves, II: Suspended transport*. Journal of Hydraulic Engineering, ASCE, Vol. 133, No. 6, (pp 668-689).
- Van Rijn, L. C. (2007c). *Unified view of sediment transport by currents and waves, III: Graded beds*. Journal of Hydraulic Engineering, ASCE, Vol. 133, No. 7, (pp 761-775).
- Van Rijn, L. C. (2007d). *Unified view of sediment transport by currents and waves, IV: Application of morphodynamic model*. Journal of Hydraulic Engineering, ASCE, Vol. 133, No. 7, (pp 776-793).
- Van Rijn, L. C. (2014). *A simple general expression for longshore transport of sand, gravel and shingle*. Coastal Engineering, Vol. 90, (pp 23-39).
- Van Rijn, L.C., & Wijnberg, K.M. (1994). *One-dimensional modelling of individual waves and wave-induced longshore currents in the surf zone*. Report R 94-09, Department of Physical Geography, University of Utrecht.
- Van Rijn, L.C., & Wijnberg, K.M. (1996). *One-dimensional modelling of individual waves and wave-induced longshore currents in the surf zone*. Coastal Engineering, Vol. 28, (pp 121-145).
- Van Rijn, L.C., Walstra, D.J.R., Grasmeyer, B., Sutherland, J., Pan, S., & Sierra, J.P. (2003). *The predictability of cross-shore bed evolution of sandy beaches at the time scale of storms and seasons using process-based profile models*. Coastal Engineering, Vol. 47, (pp 295-327).
- Viðarsdóttir, S. (2019). *Hydrodynamic numerical model of waves and currents at Landeyjahöfn Harbour*. Masters thesis. School of Engineering and Natural Sciences, University of Iceland.
- Viggosson, G., Jónsdóttir, I., Sigurðarson, S., & Bernódusson, J. (2005). *A Ferry and Ferry Port on the Exposed South Coast of Iceland*. Proceedings of the Second International Coastal Symposium in Iceland. Höfn, Hornafjörður.
- VSÓ ráðgjöf. (2008). *Bakkafjörühöfn, Bakkafjöruvegur og grjótnám á Seljalandsheiði*. Frummatsskýrsla.
- VSÓ ráðgjöf. (2020). *Viðhaldsdýpkun í Landeyjahöfn*. Efnislosun í sjó. Frummatsskýrsla.

Annex

A. SEDHAR-SAND: Sedimentation of sand and mud in harbour entrance and basin

1 Introduction

Many harbour entrances suffer from sedimentation problems of sand, silt and mud due to both currents and waves causing navigation problems for ships entering the harbour.

The annual sedimentation rate is strongly related to the physical and environmental conditions and the geometric configuration of the harbour entrance. Wind, tide- and wave-induced flows and stirring of sediments have an important role when the basin is situated along a sea or a lake (large-scale outside area).

The deposition of sand inside the harbour entrance and the approach channel is caused by the following processes:

- inflow of suspended sediment (clay, silt, sand) and during tidal filling of the harbour basin in conditions with currents and combined current and waves;
- exchange of suspended sediment (clay, silt, sand) due to horizontal circulation flows in harbour entrance;
- inflow of suspended sediment (clay, silt and sand) due to horizontal near-bed flows generated by fluid density differences (fresh/brackish water may be present in basin);
- inflow of suspended sediment due to wave asymmetry effects;
- trapping of sand in approach channel due to flow velocity reduction in deeper channel;
- wind blown sand may also contribute to harbour deposition.

This document describes the expressions used in the model SEDHAR-SAND. This model can be used to estimate the annual sedimentation in a harbour entrance due to sand. Small background concentrations of silt and mud can be included. When mud is dominant (in tidal rivers), the spreadsheet model SEDHAR-MUD should be used.

2 Flow patterns and water exchange in harbour basins

2.1 General

The fluid volume entering or leaving the entrance of a harbour consists of the following contributions:

- filling and emptying (advective processes) of the tide (V_t),
- horizontal eddy circulation (diffusive processes) generated in the entrance by the main flow outside the entrance (V_h),
- vertical circulation in the entrance generated by density differences between the fluid inside and outside the basin (V_d);
- fresh water discharged into the basin by a small river or drainage water ($V_{d,a}$).

The total water exchange volume (passing the entrance opening) per tide is: $V_e = V_t + V_h + V_d + V_{d,a}$

Sediments (mud, silt and sand) stirred up from the bed outside the basin entrance by the action of currents and waves can be transported into the basin by (generally weak) currents due to tidal filling and

horizontal circulation and density differences. Inside the basin the wave height and current velocities generally decrease rapidly resulting in a reduction of the sediment transporting capacity and hence in sedimentation in the entrance area.

2.2 Exchange processes in steady river flow and non-steady tidal flow

Steady river flow

The horizontal exchange of water in the entrance of a small harbour basin along a river due to the generation of a gyre (circulation zone) in the entrance has been studied experimentally and theoretically by Booij (1986). Various types of entrance geometries have been studied, see **Figure 2.1**. The basic data of the tests are shown in **Table 2.1**. The exchange discharges are estimates based on measured and calculated gyre velocities.

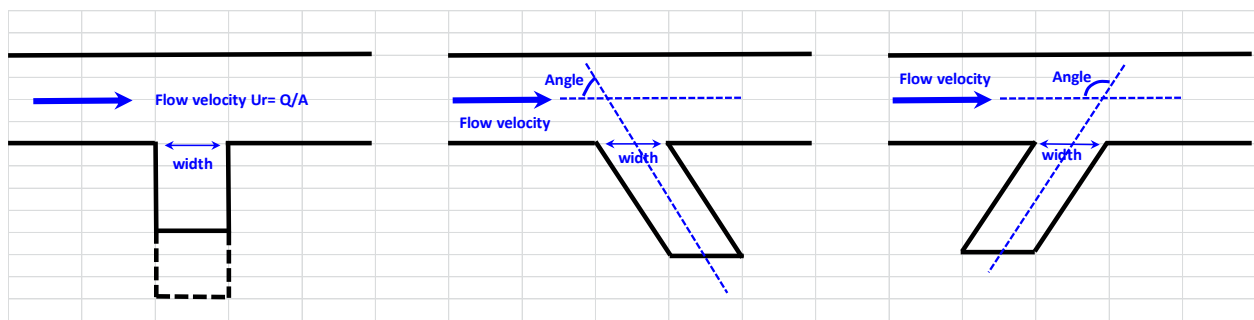

Figure 2.1 Various harbour geometries (angles of 90°, 45° and 135°)

| Type of harbour basin | Length of basin L (m) | Entrance width of basin B _e (m) | Entrance depth of basin h _e (m) | River velocity U _r (m/s) | Maximum gyre velocity U _n (m/s) | Exchange discharge Q _e (litres/s) | Exchange coefficient k (-) |
|-------------------------------------|-----------------------------|--|--|---|--|--|----------------------------------|
| 1. perpendicular to main flow (90°) | 1, 3 | 1 | 0.105 | 0.5 | 0.13 | 1.6-3.8 | 0.032-0.076 |
| 2 Oblique to main flow (45°) | 3 | 1 | 0.105 | 0.5 | 0.16 | 2.7-3.9 | 0.054-0.078 |
| 3. Oblique to main flow (135°) | 3 | 1 | 0.105 | 0.5 | 0.08 | 1.0-2.1 | 0.02-0.042 |

Table 2.1 Basic data of harbour exchange experiments; fresh water (Booij, 1986)

Assuming a linear velocity distribution, the exchange discharge Q_e can be determined (**Figure 2.2**), as follows:

$$Q_e = (0.5 U_{n,max}) (0.5B_e) h_e = 0.25 U_{n,max} B_e h_e \quad (2.1)$$

Using $U_{n,max} = k_v U_r$, it follows that:

$$Q_e = 0.25 k_v U_r B_e h_e = k U_r B_e h_e \quad (2.2)$$

with: $k = 0.25 k_v$ = exchange coefficient, U_r = river velocity, $U_{n,max}$ = maximum exchange velocity, B_e = entrance width, h_e = entrance depth.

The k -values of the steady flow experiments of Booij (1986), given in **Table 2.1**, are derived from the available exchange discharge values.

Equation (2.2) shows that the exchange discharge Q_e can be reduced by reducing the k -coefficient, the entrance width and the entrance depth. The width can be reduced by using pile screens and training walls. The depth can be reduced by using a sill at the bottom of the entrance.

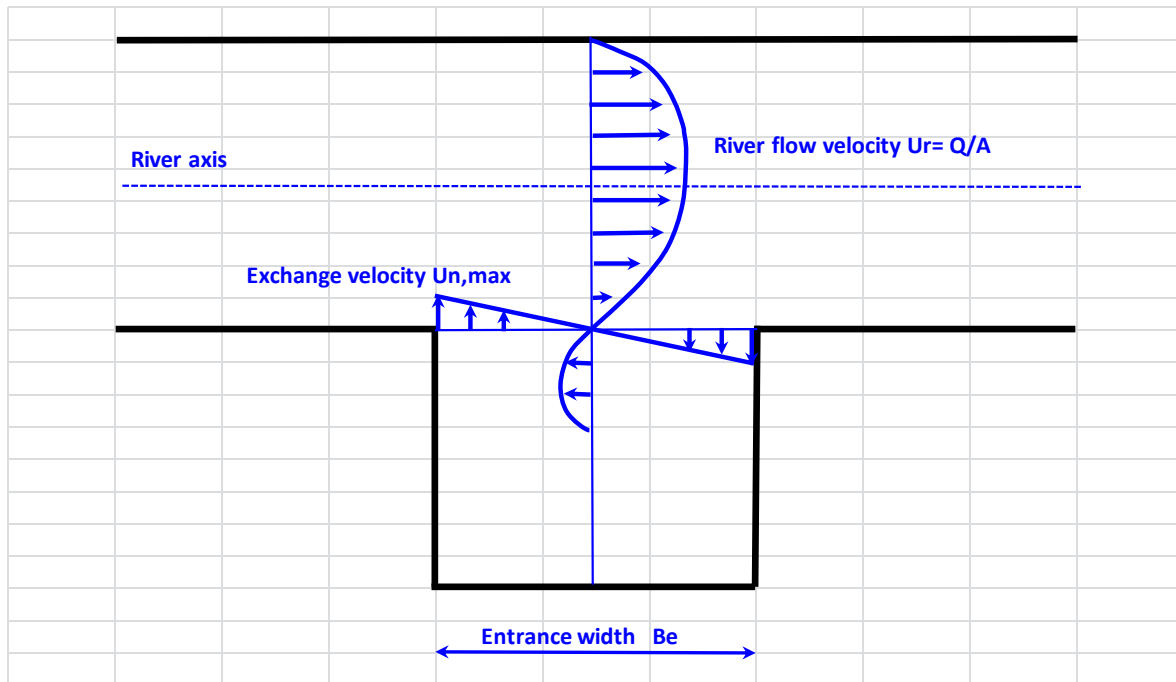

Figure 2.2 Exchange velocity in entrance of harbour basin (steady flow)

Non-steady tidal flow

The exchange of water in the entrance of a small harbour basin along a tidal river has been studied experimentally by Deltares (1977), Langendoen (1992) and Langendoen et al. (1994). Various types of entrance geometries have been studied by these researchers. Based on these results, the tide-averaged exchange coefficient k is in the range of 0.035 to 0.04.

In the case of an oblique orientation of the harbour basin, the exchange discharge was found to be about 30% smaller. The exchange discharge is about 2 to 3 larger during conditions with saline seawater and fresh river water due to the generation of density-induced vertical circulation between the harbour basin and the river.

Langendoen et al. (1994) have studied the horizontal exchange in tidal conditions with fresh water only (constant density). Various entrance geometries have been studied (perpendicular and oblique orientation). The exchange coefficient was derived from temperature measurements during tracer experiments using (well-mixed over depth) heated water injections in the entrance area. The tide-averaged k -coefficient is in the range of 0.019 to 0.023.

General expression for k -coefficient

Given all results for steady and non-steady flow, the k -values are assumed to be in the range of 0.02 to 0.05.

Herein, the following values are proposed to be used:

$k_{90} = 0.03$ for a harbour basin perpendicular to the main river flow,

$k_{45} = 0.04$ for a harbour basin oblique (45°) to the main river flow (or tidal ebb flow),

$k_{135} = 0.02$ for a harbour basin oblique (135°) to the main flow (or tidal ebb flow).

These values can be represented by the following expression:

$$k_\alpha = [1 + 0.007 (90 - \alpha)] k_{90} \quad (2.3)$$

with: α = harbour orientation angle (between 0° and 180°) and $k_{90} = 0.03$ = exchange coefficient for angle of 90° .

3 Sedimentation processes in harbour basins

3.1 Sedimentation processes

The sedimentation in a harbour entrance basically consists of the following processes:

- sediments supplied from upstream (bypassing) entering the entrance through exchange (eddies, density currents) processes in the entrance area;
- sediments supplied from upstream (bypassing) by currents entering the entrance area in situations with asymmetric breakwaters;
- sediments supplied from downstream by recirculation currents near the downstream shore;
- sediments supplied by diffractive wave effects around the tip of the breakwaters;
- bars migrating along the protruding harbour entrance (bypassing).

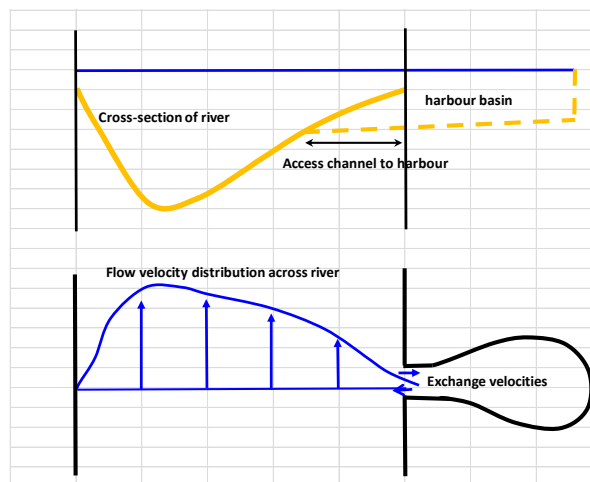

Figure 3.1 Small harbour basin along riverbank

A small harbour basin along a riverbank generally has an entrance in relatively shallow water (depths of 4 to 6 m). Water can only enter the basin due to exchange currents in the entrance of the harbour and due to the (slow) filling process during flood stages. **Figure 3.1** shows a small harbour basin along a riverbank. The sedimentation is mainly caused by the horizontal exchange currents due to the formation of circulation flows in the entrance area.

3.2 Prediction of sedimentation volumes by semi-empirical method

Herein, a semi-empirical spreadsheet model SEDHAR-SAND, based on tide-averaged variables, is described.

The input values for velocity and water depth are specified as daily, weekly or monthly-averaged values.

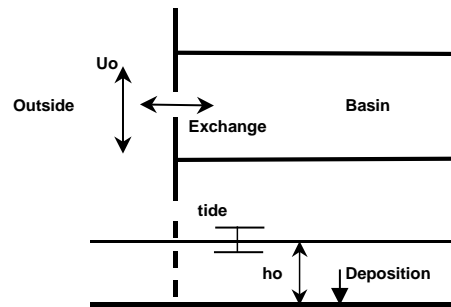

Figure 3.2 Schematized harbour basin (top view and side view)

The sediment discharge of sand, silt and mud (Q_s) into the harbour basin can be described as:

$$Q_s = 0.5 B_e h_e U_{in} C_{outside} \quad (3.1)$$

with:

- Q_s = sediment discharge (kg/s); U_{in} = total tide-averaged depth-averaged inflow velocity;
- B_e = width of harbour entrance; h_e = tide-averaged water depth of harbour entrance;
- $C_{outside}$ = tide-averaged and depth-averaged sediment concentration outside the harbour entrance.

The total inflow velocity can be expressed, as:

$$U_{in} = U_{ex} + U_{tide} + U_{dd1} + U_{dd2} + U_{pump}$$

$$U_{in} = 2 f_{ex} U_{outside} + (A_{basin} \Delta H) / (B_e h_e 0.5 T) + f_{dd} [(\Delta \rho_o / \rho_o) g h_e]^{0.5} + Q_{fresh} / (B_e h_e) + Q_{pump} / (B_e h_e) \quad (3.2)$$

with:

- U_{ex} = horizontal exchange velocity (m/s) due to eddy circulation during 50% to 70% of the time; not during peak ebb flow when the eddy is disrupted;
- U_{tide} = tide-averaged filling velocity (m/s) into basin during flood period (50% of the time);
- U_{dd1} = tide-averaged density-driven velocity (m/s) into basin during 50% of the time (if density outside is larger than that inside basin; only for basins near coast with outside seawater);
- U_{dd2} = tide-averaged density-driven velocity (m/s) into basin due to fresh water input into basin (from land sources; drainage water into basin; only relevant for basin near coast);
- U_{pump} = velocity into basin due to pump discharge in basin (m/s);
- Q_{pump} = annual-averaged pump discharge inside basin (m^3/s);
- Q_{fresh} = annual-averaged freshwater discharge from land into basin (m^3/s);
- T = tidal period (s); A_{basin} = area of basin (m^2); ΔH = tidal range (m);
- $\Delta \rho_o$ = maximum density difference between outside and inside of basin (range of 0 to 3 kg/m^3);
- ρ_o = fluid density outside basin (1000 to 1030 kg/m^3);
- f_{ex} = exchange coefficient (0.01 to 0.05);
- f_{dd} = coefficient ($\cong 0.4$).

The tide-averaged and depth-averaged sediment concentration outside the basin can be expressed as:

$$C_{\text{outside}} = C_{\text{sand}} + C_{\text{silt}} + C_{\text{mud}} \quad (3.3)$$

with:

C_{sand} = depth-averaged sand concentration (sediment > 0.06 mm), (kg/m³);

C_{silt} = depth-averaged silt concentration (sediment between 0.02 and 0.06 mm; input value kg/m³);

C_{mud} = depth-averaged mud concentration (sediment between 0.005 and 0.02 mm; input value kg/m³).

The tide-averaged and depth-averaged sand concentration is computed from an empirical sand transport equation, as:

$$C_{\text{sand}} = (q_b + q_s) / (U_{\text{outside}} h_{\text{outside}}) \quad (3.4)$$

with:

q_b = bed load transport of sand (kg/m/s);

q_s = suspended load transport of sand (kg/m/s);

U_{outside} = effective depth-averaged flow velocity outside entrance of harbour (m/s);

h_{outside} = tide-averaged water depth outside entrance of harbour (m).

The simplified bed load-load transport formula for steady flow (with or without waves) reads, as (Van Rijn 2007):

$$q_b = \alpha_b (1 - 0.01 p_{\text{mud}}) \rho_s U_{\text{outside}} h_{\text{outside}} (d_{50}/h_{\text{outside}})^{1.2} M_e^{1.5} \quad (3.5)$$

with:

q_b = bed load transport (kg/s/m); α_b = coefficient = 0.015

$M_e = (U_e - U_{cr}) / [(s-1)gd_{50}]^{0.5}$ = mobility parameter (-);

$U_e = U_{\text{outside}} + \gamma U_w$ = effective velocity (m/s) with $\gamma = 0.4$ for irregular waves (and 0.8 for regular waves);

U_{outside} = tide-averaged and depth-averaged flow velocity outside harbour entrance (m/s);

$U_w = \pi H_s / [T_p \sinh(kh)]$ = peak orbital velocity (m/s) based on linear wave theory;

H_s = significant wave height outside entrance (m); T_p = peak wave period (s); k = wave number = $2\pi/L$ (1/m);

L = wave length outside entrance (m);

d_{50}, d_{90} = particle sizes (m); p_{mud} = percentage of mud (0 to 30%); $s = \rho_s / \rho_w$ = relative density (-);

ρ_s = sediment density (kg/m³); ρ_w = fluid density (kg/m³);

$U_{cr} = \beta U_{cr,c} + (1-\beta)U_{cr,w}$ = critical velocity (m/s) for initiation of motion; with $\beta = U_{\text{outside}} / (U_{\text{outside}} + U_w)$;

$U_{cr,c}$ = critical velocity for currents based on Shields (initiation of motion see Van Rijn, 1993);

$U_{cr,w}$ = critical velocity for waves based (see Van Rijn, 1993);

$U_{cr,c} = 0.19 (1+0.01p_{\text{mud}})^{1.5} (d_{50})^{0.1} \log(12h_{\text{outside}}/3d_{90})$ for $0.0001 < d_{50} < 0.0005$ m;

$U_{cr,c} = 8.5 (1+0.01p_{\text{mud}})^{1.5} (d_{50})^{0.6} \log(12h_{\text{outside}}/3d_{90})$ for $0.0005 < d_{50} < 0.002$ m;

$U_{cr,w} = 0.24 (1+0.01p_{\text{mud}})^{1.5} [(s-1)g]^{0.66} d_{50}^{0.33} (T_p)^{0.33}$ for $0.0001 < d_{50} < 0.0005$ m;

$U_{cr,w} = 0.95 (1+0.01p_{\text{mud}})^{1.5} [(s-1)g]^{0.57} d_{50}^{0.43} (T_p)^{0.14}$ for $0.0005 < d_{50} < 0.002$ m.

The simplified suspended load transport formula for steady flow with and without waves reads, as (Van Rijn 2007):

$$q_s = \alpha_s (1-0.01 p_{\text{mud}}) \rho_s U_{\text{outside}} d_{50} M_e^{2.4} (D^*)^{-0.6} \quad (3.6)$$

with:

q_s = suspended load transport (kg/s/m);

h_{outside} = tide-averaged water depth outside entrance (m);

d_{50} = particle size (m); $D^* = d_{50} [(s-1)g/v^2]$ = dimensionless particle size (-);

- $\alpha_s = 0.008$ (coefficient); $s = \rho_s/\rho_w$ =relative density (-); ν = kinematic viscosity (m^2/s);
 $M_e = (U_e - U_{cr})/[(s-1)gd_{50}]^{0.5}$ = mobility parameter (-);
 U_e = effective tide-averaged and depth-averaged velocity (m/s); see Equation (3.5)
 U_{cr} = critical depth-averaged velocity for initiation of motion (m/s), see Equation (3.5).

The sedimentation mass M_s in the entrance and basin can be determined by summation over time:

$$\begin{aligned} M_s &= M_{sand,c} + M_{silt,c} + M_{mud,c} + M_{sand,w} \\ M_s &= (e_{sand} Q_{s,sand,c} + e_{silt} Q_{s,silt,c} + e_{mud} Q_{s,mud,c}) \Delta t \\ M_s &= (e_{sand} C_{sand} + e_{silt} C_{silt} + e_{mud} C_{mud}) 0.5B_e h_e U_{in} \Delta t \end{aligned} \quad (3.7)$$

with:

- $M_{sand,c}$ = sedimentation mass (kg) of sand supplied by current (with or without waves), silt and mud;
 $M_{silt,c}$ = sedimentation mass (kg) of silt supplied by current (with or without waves);
 $M_{mud,c}$ = sedimentation mass (kg) of mud supplied by current (with or without waves);
 $M_{sand,w}$ = sedimentation mass (kg) of sand supplied by wave asymmetry effect;
 Q_s = sediment transport through entrance (kg/s);
 e_{sand} = trapping factor sand (=1);
 e_{silt} = trapping factor silt;
 e_{mud} = trapping factor mud;
 Δt = time period considered (1 day, 7 days or 30 days; minimum = 1 day).

The trapping factors of silt and mud are determined from the ratio of the residence time T_R and the settling time of fine particles T_s over the depth of the basin, as follows:

$$e_{silt} = T_R/T_{s,silt} \quad (3.8)$$

$$e_{mud} = T_R/T_{s,mud} \quad (3.9)$$

with:

- $T_R = V_{basin}/Q_w$ = residence time (s);
 $Q_w = 0.5B_e h_e U_{in}$ = total inflow discharge of water through entrance (m^3/s);
 $V_{basin} = A_{basin} h_{basin}$ = basin volume (m^3);
 $T_{s,silt} = h_{basin}/w_{s,silt}$ = settling time of silt in basin (s);
 $T_{s,mud} = h_{basin}/w_{s,mud}$ = settling time of mud in basin (s);
 $w_{s,silt}$ = settling velocity of silt (input value, m/s);
 $w_{s,mud}$ = settling velocity of mud (input value, m/s).

The mass of sand passing the harbour entrance due to wave asymmetry effects is crudely given by:

$$M_{sand,w} = 0.1 U_w \delta C_{sand} B_e \Delta t \quad (3.10)$$

with: U_w = peak orbital velocity, δ =layer thickness=0.2h, h= water depth, C_{sand} = depth-averaged sand concentration due to combined current and waves, B_e = width of entrance, Δt = time period.

The sedimentation volume V_s is computed as:

$$V_{s,entrance} = M_{sand}/\rho_{bulk,sand} + M_{silt}/\rho_{bulk,silt} + M_{mud}/\rho_{bulk,mud} \quad (3.11)$$

with:

- V_s = sedimentation volume (m^3);
 $\rho_{bulk,sand}$ = bulk density of sand (input value, 1600 kg/m^3);
 $\rho_{bulk,silt}$ = bulk density of silt (input value, 1600 kg/m^3);
 $\rho_{bulk,mud}$ = bulk density of mud (input value, 1100 to 1300 kg/m^3).

If an access channel between the harbour entrance and deeper water is present, the sedimentation volume of the access channel is computed as:

$$V_{s,\text{access}} = (q_b + q_s) e_a \Delta t \sin\beta L_a / \rho_{\text{bulk, sand}} \quad (3.12)$$

$$e_a = 1 - \exp[-\eta d_a (B_a / \sin\beta) / h_a^2] = \text{trapping efficiency}$$

$$\eta = 0.25(w_{s,\text{sand}} / U^*) (1 + 2w_{s,\text{sand}} / U^*) = \text{coefficient}$$

With:

$V_{s,\text{access}}$ = sedimentation volume of access channel (m^3);

L_a = length of access channel (m);

B_a = width of access channel (m);

h_a = depth in access channel (m);

d_a = depth of access channel below riverbed (m);

β = angle of access channel axis with river flow (degrees);

U^* = bed-shear velocity = $(g^{0.5} / C) U_{\text{outside}}$ (m/s);

C = $5.75 g^{0.5} \log(12h_{\text{outside}} / k_s)$ = Chézy coefficient ($\text{m}^{0.5} / \text{s}$);

$w_{s,\text{sand}}$ = settling velocity of sand.

Equations (3.1) to (3.12) are implemented in the spreadsheet-model **SEDHAR-SAND**.

5. References

- Booij, R., 1986.** Measurements of water exchange between river and harbour (in Dutch). Report No 9-86. Delft University of Technology, Delft, The Netherlands
- Deltares, 1977.** *Influence of harbour on salinity and exchange discharge between harbour and tidal river (in Dutch). Report M896-36. Delft, The Netherlands*
- Langendoen, E.J., 1992.** *Flow patterns and transport of dissolved matter in tidal harbours. Ph.D. Thesis, Civil Engineering, Delft University of Technology, Delft. The Netherlands*
- Langendoen, E.J., Kranenburg, C. and Booij, R., 1994.** *Flow patterns and exchange of matter in tidal harbours. Journal of Hydraulic Research, Vol. 32, No 2, 259-270*
- Van Rijn, L.C. 1993, 2012.** *Principles of sediment transport in rivers, estuaries and coastal seas. Aqua Publications, The Netherlands. www.aquapublications.nl*
- Van Rijn, L.C., 2007.** *Unified view of sediment transport by currents and waves, I: Initiation of motion, bed roughness, and bed-load transport. Journal of Hydraulic Engineering, 133(6), p 649-667.*
- Van Rijn, L.C., 2007.** *Unified view of sediment transport by currents and waves, II: Suspended transport. Journal of Hydraulic Engineering, 133(6), p 668-389.*